

PE552-E110  
 PE552-E220  
 PE552A-E110  
 PE552A-E220  
 PE552S-E110

PE552S-E220  
 PE554-E110  
 PE554-E220  
 PE554S-E110  
 PE554S-E220

## MODEL C ELECTRIC HYDRAULIC PUMP

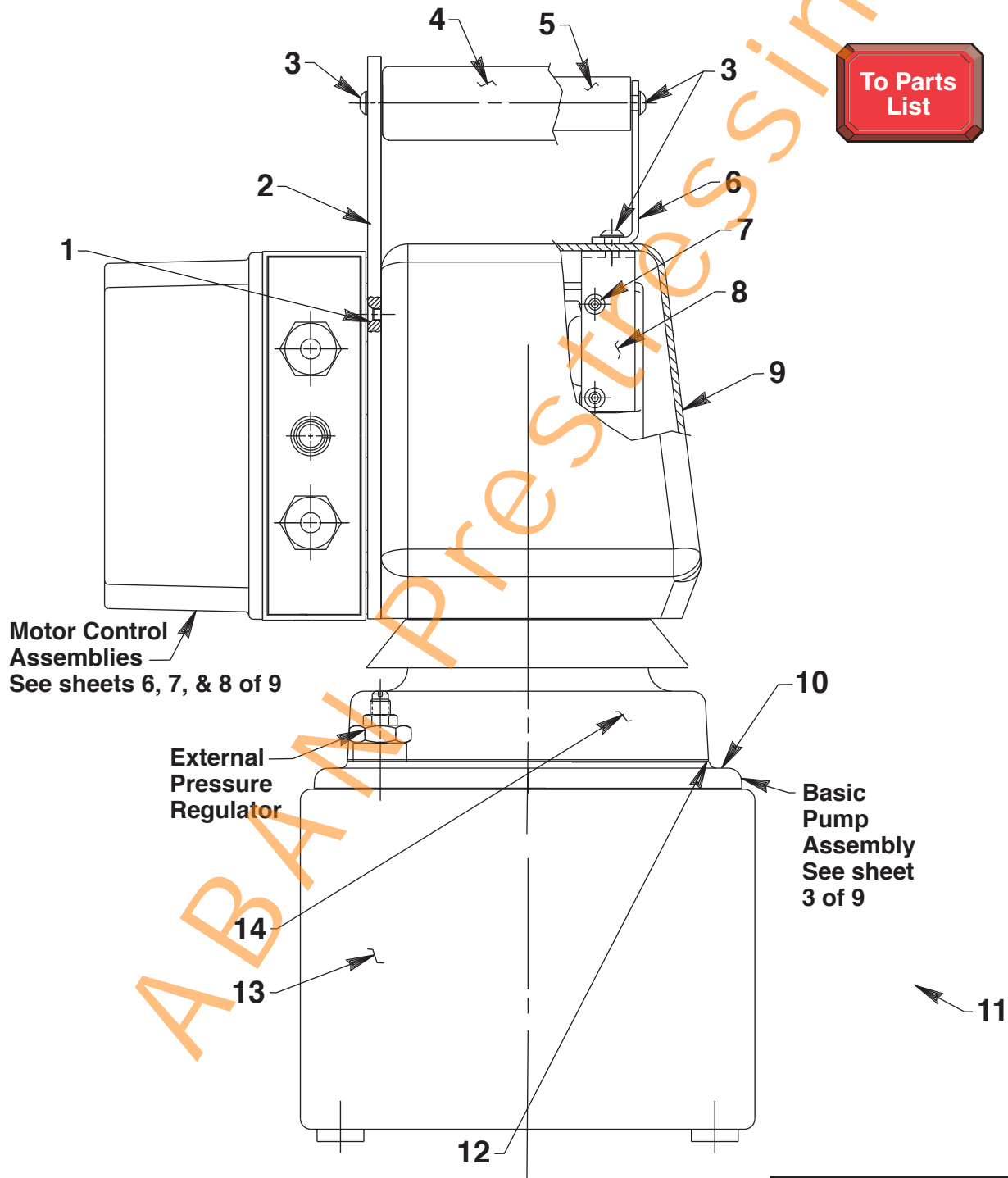

Item No.	Part No.	No. Req'd	Description
1	253140	3	Flat Hd. Screw (10-24 x 5/8)
2	59028BK2	1	Mounting Bracket
3	251437	7	Button Hd. Screw (1/4-20 x 1/2)
4	216668	1	Handle Grip
5	252020	1	Handle
6	351189BK2	1	Handle Bracket
7	251486	4	Button Hd. Screw (10-24 x 1/2)
8	421212	1	Bracket
9	65053	1	Cover
10	9582	1	2-Way Valve (For PE552-E110 & PE552-E220; See Form No. 101248)
	9610	1	3-Way Auto. Valve (For PE552A-E110 & PE552A-E220; See Form No. 101200)
	421547	1	3-Way 115V Solenoid Valve (For PE552S-E110; See Form No. 101803)
	421451	1	3-Way 220V. Solenoid Valve (For PE552S-E220; See Form No. 101803)
	9506	1	4-Way Manual Valve (For PE554-E110 & PE554-E220; See Form No. 100628)

Item No.	Part No.	No. Req'd	Description
	66206-110	1	4-Way 110V. Solenoid Valve (For PE554S-E110; See Form No. 108066)
	66206-220	1	4-Way 230V. Solenoid Valve (For PE554S-E220; See Form No. 108066)
11	40063OR9	1	Reservoir (2 gallon)
12	30650	1	Motor Base Gasket
13	309219	2	Trade Name Decal
14	65249	1	Motor Assembly (110V) } See sheet
	65065	1	Motor Assembly (220V) } 2 of 9

**PARTS INCLUDED BUT NOT SHOWN**

10022	4	Soc. Hd. Screw (1/4-20 x 1-1/2; For mounting motor to pump.)
12409	4	Rnd. Hd. Screw (8-32 x 5/8; Mounts motor control assembly to pump.)
252047	1	Pictogram Instruction Decal (Located near pressure regulator.)
9689	1	Reducer Connector } For PE554S-E110
16797	1	90° Elbow Fitting } & PE554S-E220



**HYDRAULIC SCHEMATIC**

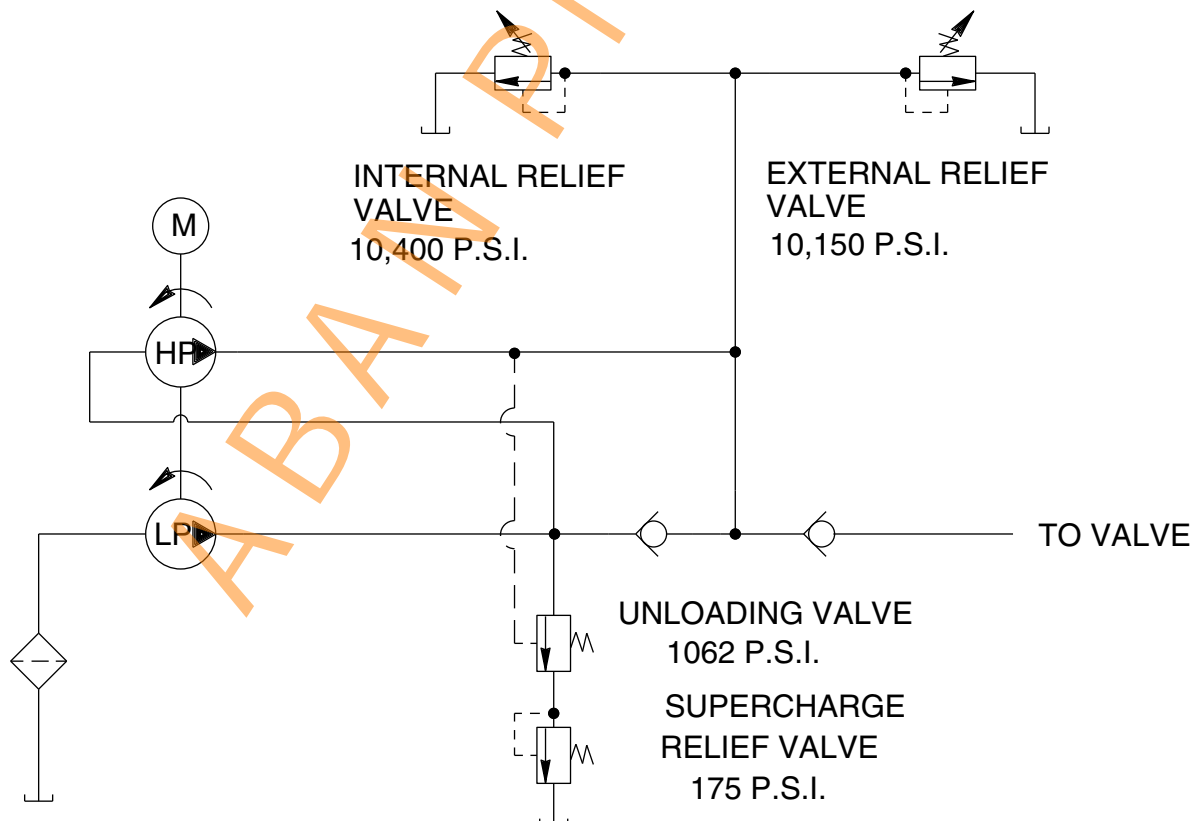

# UNIVERSAL MOTOR

12,000 RPM, 115 & 230 Volt, 50/60 Hz.

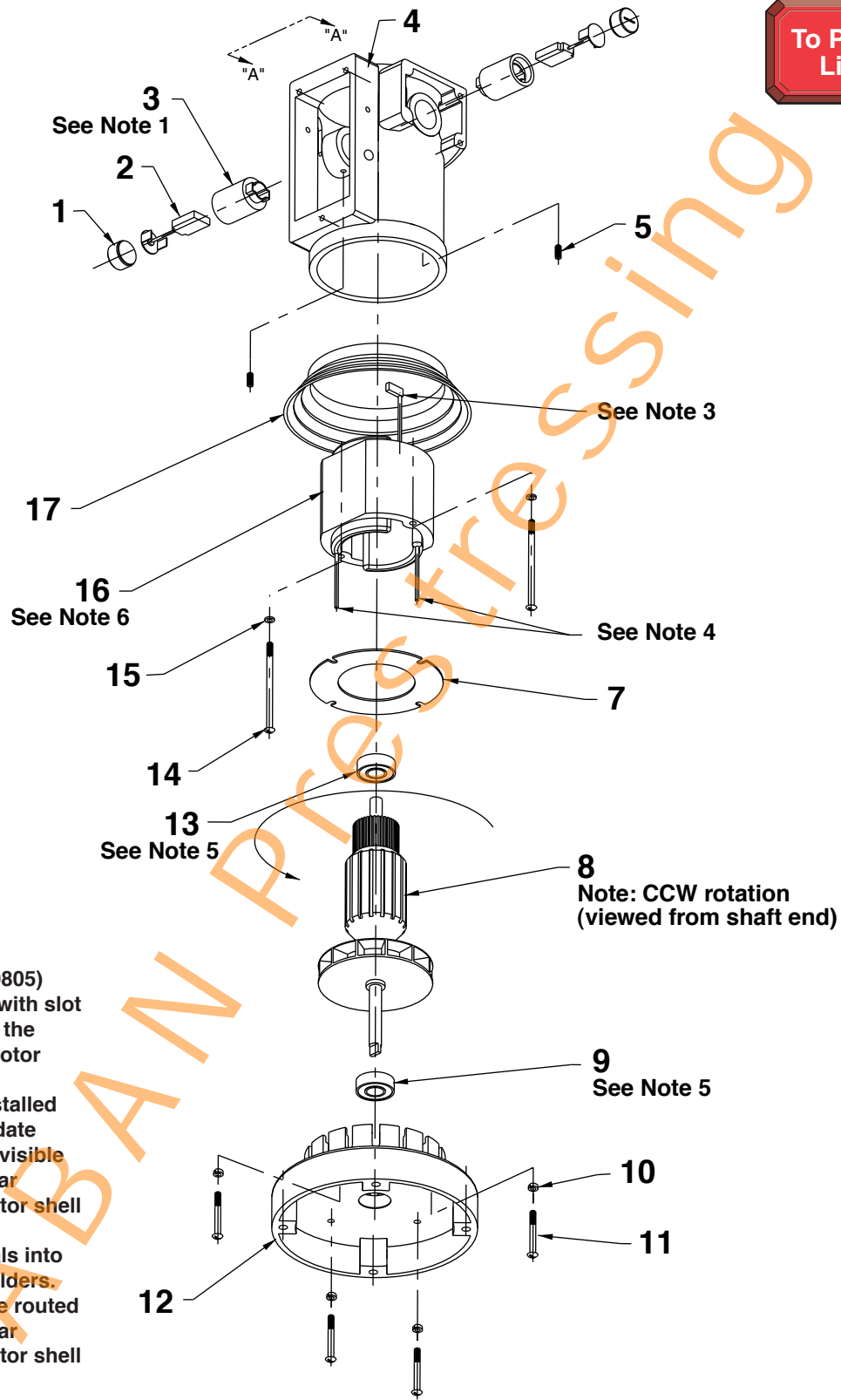

**Notes:**

1. Bush holders (#10805) must be installed with slot and dimple facing the open end of the motor shell casting.
2. Stator must be installed with part no. and date code up (must be visible thru the rectangular opening in the motor shell casting).
3. Insert flag terminals into adjacent brush holders.
4. Line leads must be routed thru the rectangular opening in the motor shell casting.
5. Press bearings into armature and install as a unit into the motor shell casting.

Item No.	Part No.	No. Req'd	Description
1	10806	2	Brush Holder Cap
2	10804	2	Brush
3	10805	2	Brush Holder
4	65064	1	Motor Shell
5	10133	2	Set Screw (#10-24 UNC X 1/4 Lg.)
7	20786	1	Baffle Plate
8	10801	1	Armature (230 volt)
	10800	1	Armature (115 volt)
9	10438	1	Ball Bearing
10	10241	4	Lockwasher (For #10 bolt)
11	10169	2	Screw (#10-24 UNC X 2" Lg.; Torque to 20/25 in. lbs.)
12	40059WH2	1	Motor Base
13	10439	1	Ball Bearing
14	10170	2	Screw (#10-24 UNC X 3-1/4 Lg.)
15	12356	2	Washer (#10 Internal Tooth)
16	10803	1	Field (230 volt)
	10802	1	Field (115 volt)
17	421204	1	Plastic Cover



### BRUSH HOLDER & ARMATURE INSTALLATION SPECIFICATIONS

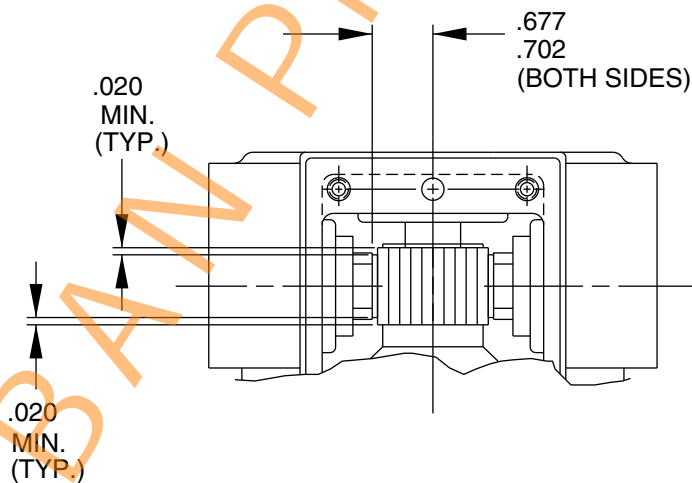

When replacing brushes or the armature, the dimensions shown must be as specified.

### GENERAL PUMP ASSEMBLY

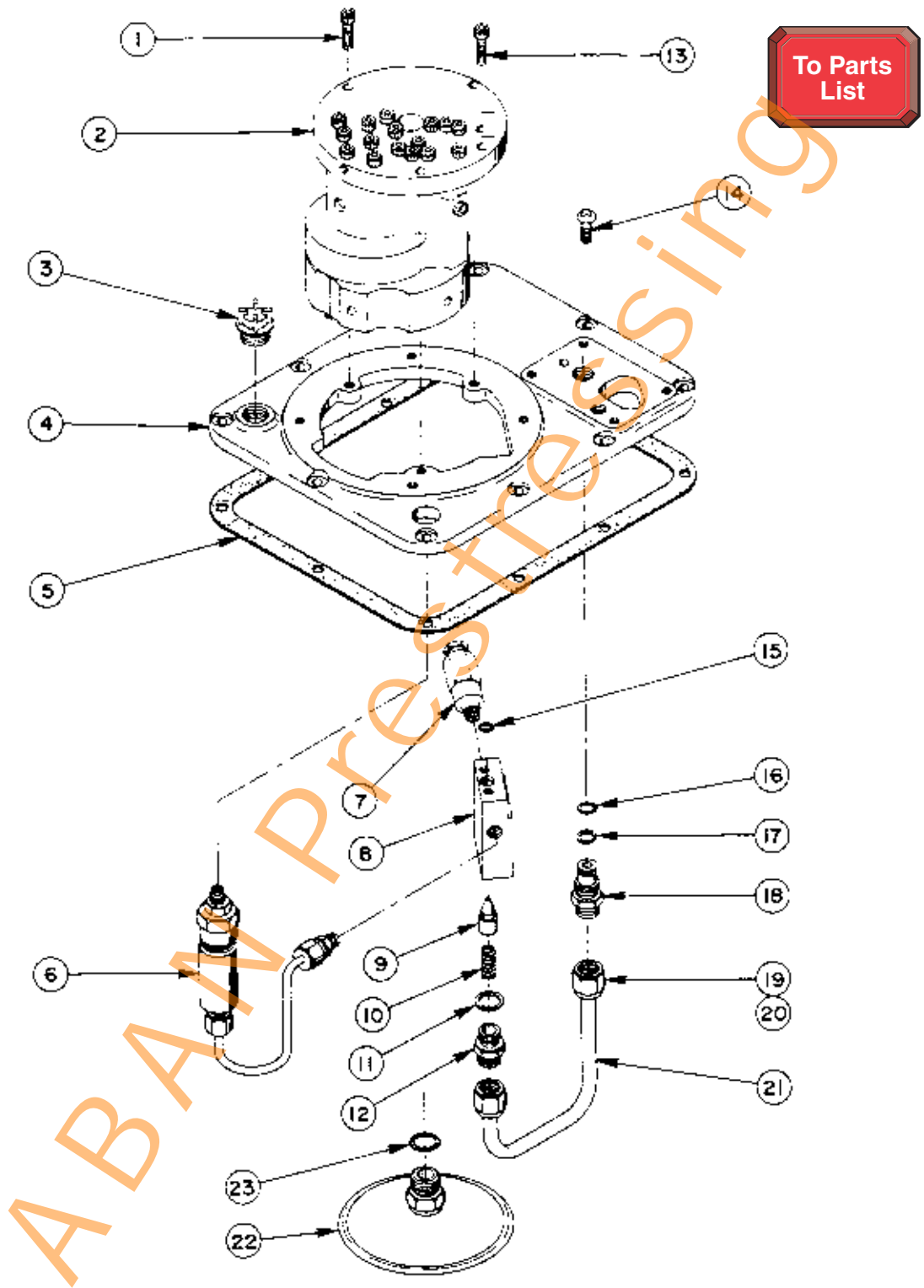

# Parts List, Form No. 108135, Back sheet 3 of 9

Item No.	Part No.	No. Req'd	Description	Item No.	Part No.	No. Req'd	Description
1	10016	3	Soc. Hd. Cap Screw (1/4-20 UNC X 1" Lg.)	11	10261	1	Copper Washer (3/4 X 19/32 X 1/32)
2	*27207	1	Basic Pump Ass'y Replacement (See chart below)	12	20770	1	Connector (Torque to 40/45 ft. lbs.)
3	20937	1	Filler Plug	13	10015	2	Soc. Hd. Cap Screw (1/4-28 UNF X 1" Lg.; Torque to 180 in. lbs.)
4	40064WH2	1	Cover	14	10177	10	Mach. Screw
5	40164	1	Gasket	15	10266	1	O-ring (3/8 X 1/4 X 1/16)
6	22360	1	Pressure Regulator Ass'y (See below)	16	10268	1	O-ring (1/2 X 3/8 X 1/16)
7	21278	1	Relief Valve (Set at 10,100/10,700 PSI)	17	11863	1	PTFE Backup Washer
8	20776	1	Valve Body	18	20787	1	Valve Connector
9	20771	1	Poppet	19	10430	2	Tube Sleeve
10	10425	1	Compression Spring (3/8 O.D. X 3/4 Lg.)	20	10431	2	Tube Nut
				21	21045	1	Oil Line
				22	21344	1	Filter Ass'y (Includes Item 23)
				23	10300	1	O-ring (5/8 X 15/32 X 5/62)



\*Includes all items on back sheet 4 of 9 and items 1, 7, 8, 9, 10, 11, 12, 13, 15 & 22 on this sheet.

Series	Max. PSI	Basic Pump & Cover Plate Ass'y	Basic Pump Replacement	High Pressure Pump Ass'y Used	No. of Pistons
PE552-E110 PE552-E220 PE552A-E110 PE552A-E220 PE552S-E110 PE552S-E220 PE554-E110 PE554-E220 PE554S-E110 PE554S-E220	10,000	50403	*27207	33113	3

## PRESSURE REGULATOR ASSEMBLY

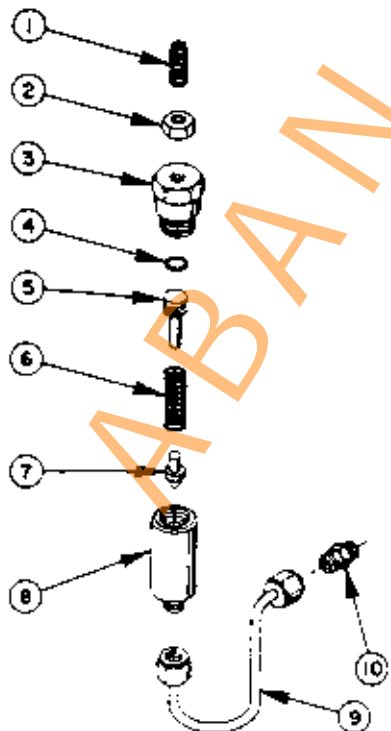

Item No.	Part No.	No. Req'd	Description
1	22362	1	Adjusting Screw
2	10386	1	Hex Jam Nut
3	21305	1	Valve Cap
4	10268	1	O-ring (1/2 X 3/8 X 1/16)
5	21306	1	Spring Guide
6	10495	1	Compression Spring (1/2 O.D. X 1-5/8 Lg.)
7	21046	1	Valve Stem
8	22361	1	Body
9	29267	1	Oil Line Ass'y (With nuts)
10	14844	1	Connector Fitting

# BASIC PUMP ASSEMBLY

To Parts List

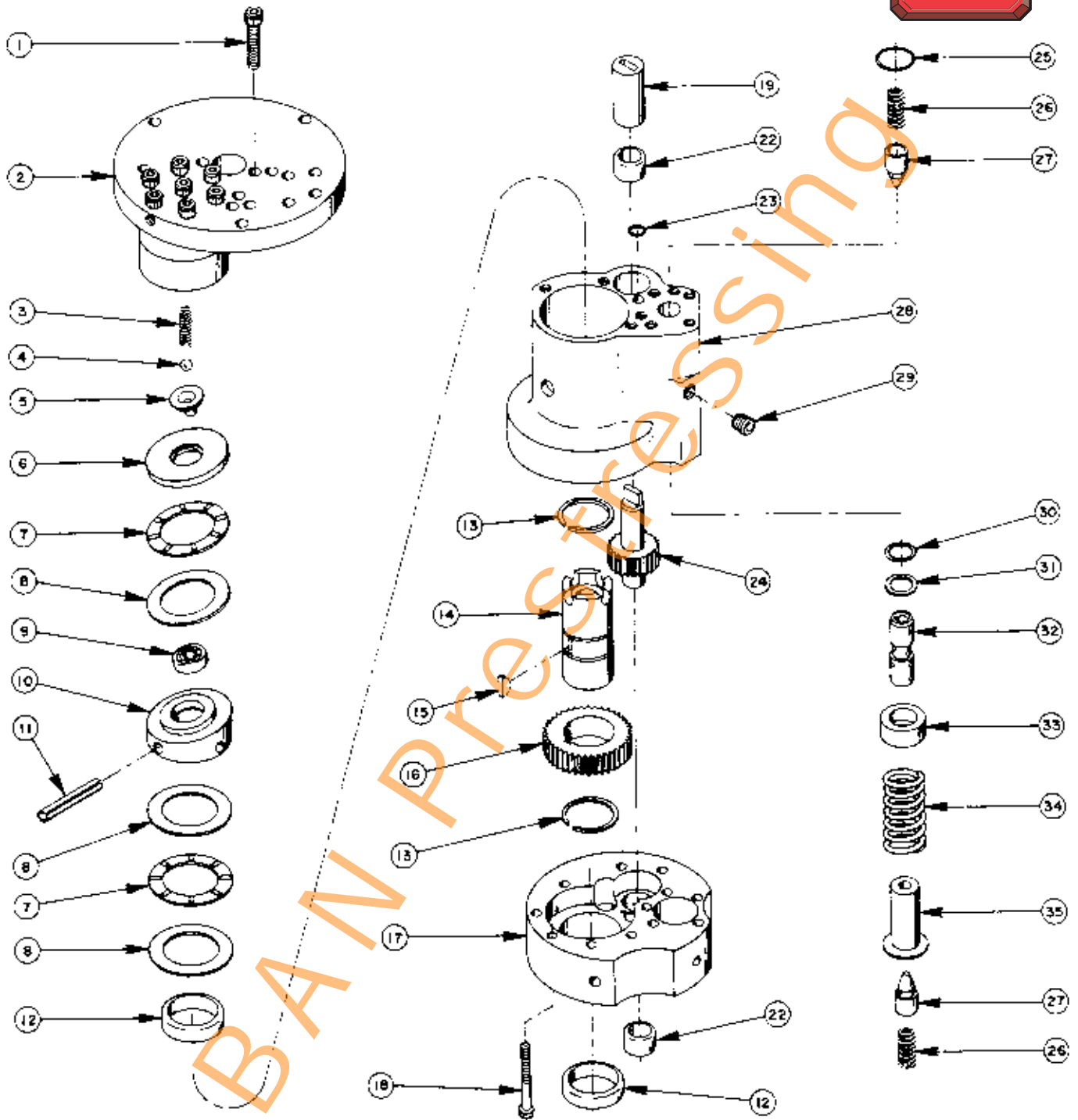

ABAN PRESS

Item No.	Part No.	No. Req'd	Description
1	10020	9	Soc. Hd. Cap Screw (1/4-20 UNC X 1-1/4 Lg.; Torque to 170-180 in. lbs.)
2	33113	1	High Pressure Pump Ass'y (See sheet 5 of 9)
3	10361	1	Compression Spring (1/4 O.D. X 1" Lg.)
4	10375	1	Steel Ball (1/4" dia.)
5	23547	1	Bearing Top Plate
6	23548	1	Top Plate
7	11228	2	Thrust Bearing
8	11813	3	Bearing Race
9	11814	1	Ball Bearing
10	23549	1	Angle Plate
11	11955	1	Roll Pin (1/4" dia. X 1-3/4 Lg.)
12	11064	2	Needle Bearing
13	11261	2	Retaining Ring
14	23556	1	Shaft
15	11821	1	Woodruff Key
16	23574	1	Gear
17	40072	1	Pump End Plate
18	10001	13	Soc. Hd. Cap Screw (#10-32 UNF X 1-3/4" Lg.; Torque to 50 in. lbs.)
19	21091	1	Coupling
20	21092	1	Adapter
21	21093	1	Key
22	11198	2	Needle Thrust Bearing (See Note below)
23	10266	1	O-ring (3/8 X 1/4 X 1/16)
24	20774	1	Drive Gear
25	10303	1	O-ring (7/8 X 3/4 X 1/16)
26	10425	2	Compression Spring (3/8 O.D. X 3/4 Lg.)
27	20771	2	Poppet
28	40071	1	Pump Body
29	10427	1	Pipe Plug (1/8" NPTF)
30	10271	1	O-ring (11/16 X 1/2 X 3/32)
31	12389	1	PTFE Backup Washer (11/16 X 1/2 X 1/16)
32	20849	1	Spool
33	23255	1	Spring Guide
34	10426	1	Compression Spring (1" O.D. X 1-13/16 Lg.)
35	23256	1	Spring Guide



### NEEDLE BEARING INSTALLATION SPECIFICATIONS

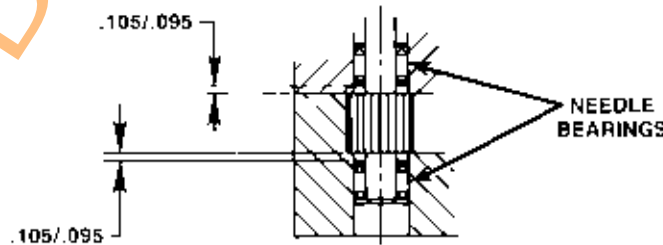

When replacing the needle bearings on the drive gear of the basic pumps, the dimensions shown must be as specified.



### HIGH PRESSURE PUMP ASSEMBLY

See Diagram on Reverse Side for Important Ass'y. Information

To Parts List

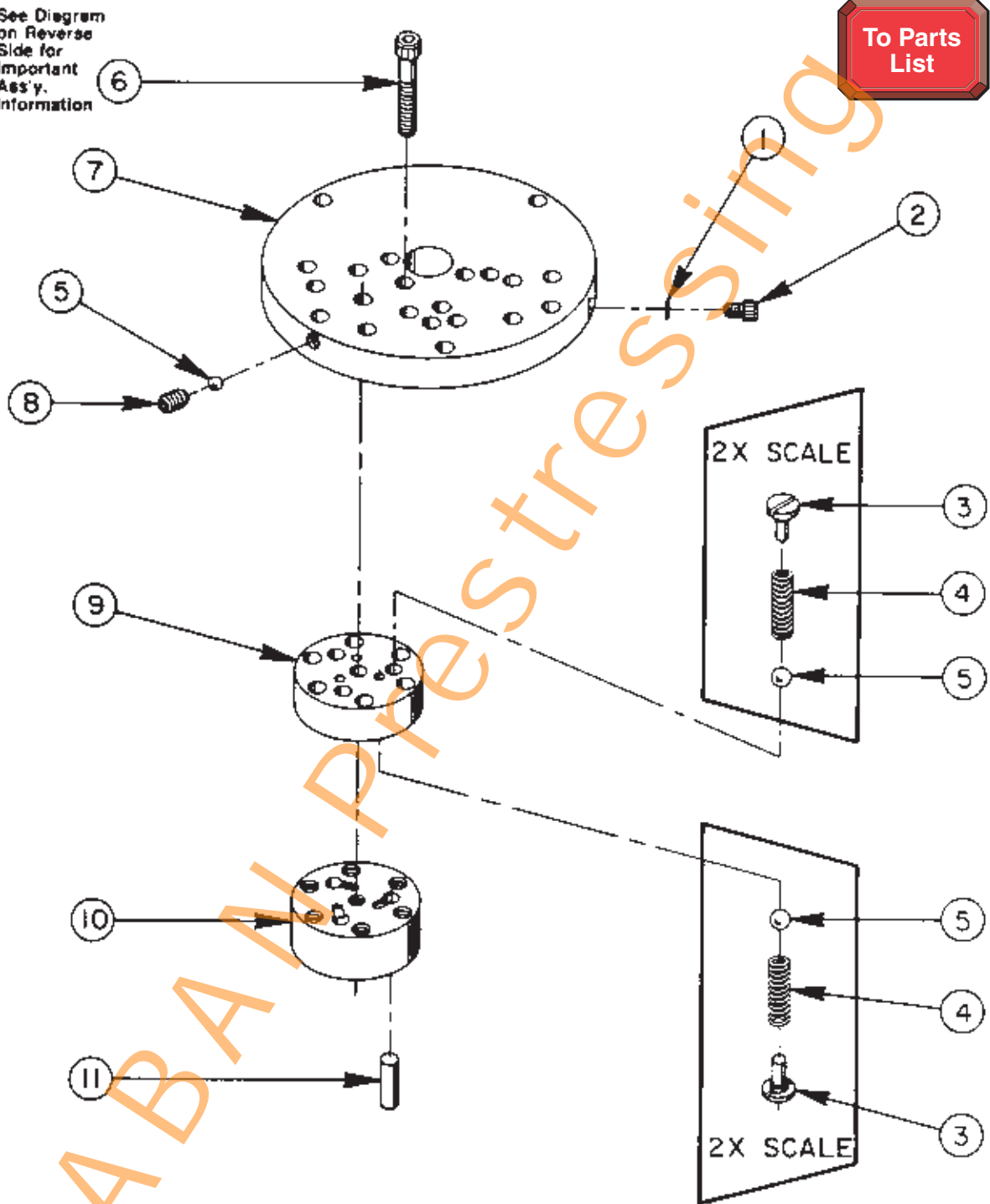

### 33113 PUMP ASS'Y

3 Pistons -- 9/32 Dia.

Item No.	Part No.	No. Req'd	Description
1	10442	1	Copper Washer (3/8 X 1/4 X 1/32)
2	10002	1	Soc. Hd. Cap Screw (1/4-20 UNC X 3/8" Lg.; Torque to 140/160 in. lbs.)
3	24549	6	Valve Guide
4	10445	6	Compression Spring (5/32" O.D. X 3/4" Lg.)
5	12223	7	Steel Ball
6	10023	7	Soc. Hd. Cap Screw (1/4-20 UNF X 1-1/2" Lg.; Torque to 170/180 in. lbs.; See note below)
7	50411	1	Top Plate
8	10519	1	Soc. Set Screw (1/4-20 UNC X 3/8 Lg.; Torque to 65/70 in. lbs.)
9	40630	1	Valve Head
10	41062	1	Pump Barrel
11	21628	3	Piston



### BOLT TIGHTENING SEQUENCE

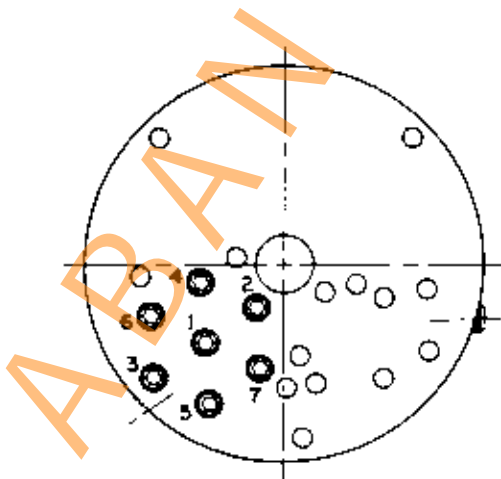

**NOTE:** Assemble in sequence shown. Lubricate under head and on threads. Torque to 180 in. lbs.

# MOTOR CONTROL ASSEMBLY FOR PE552-E110, PE552-E220, PE554-E110, PE554-E220, PE552A-E110 & PE552A-E220

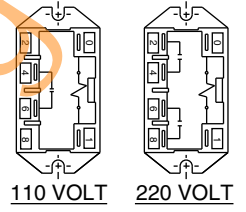

VIEW A-A

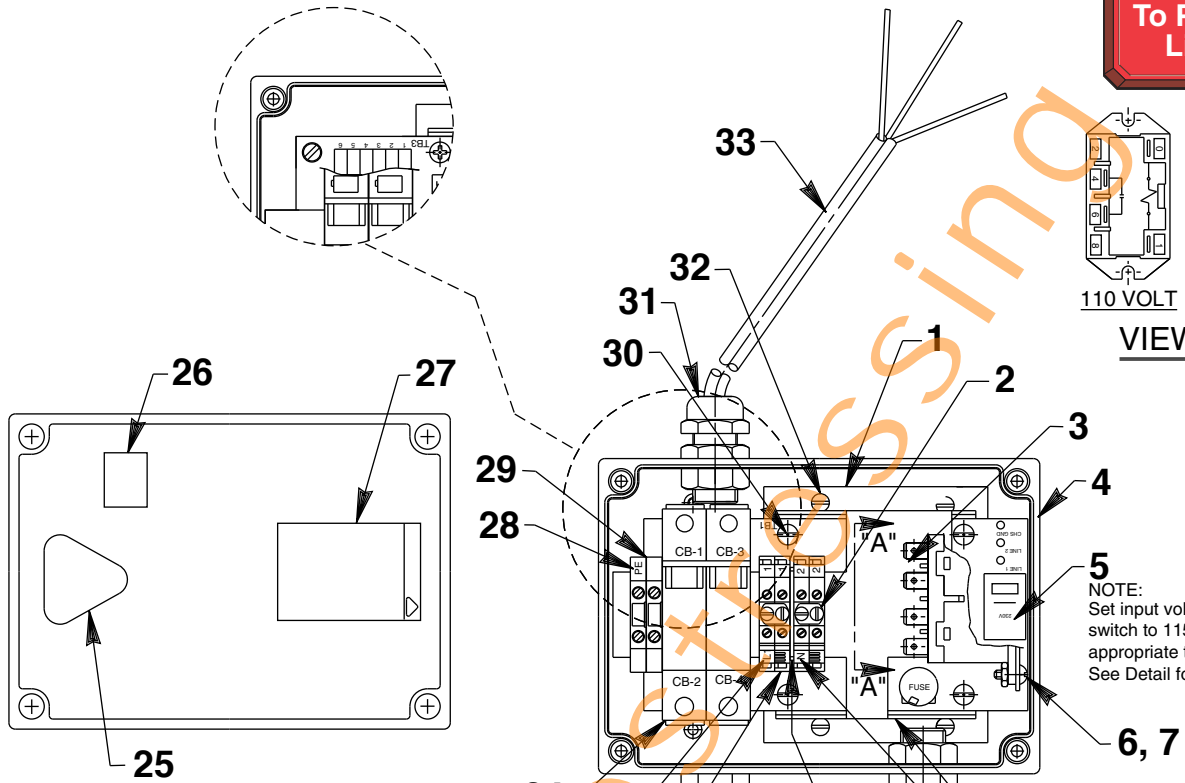

**NOTE:**  
Set input voltage selector switch to 115V. or 230V. appropriate to your pump. See Detail for jumper positions.

DECAL LOCATION BOX COVER

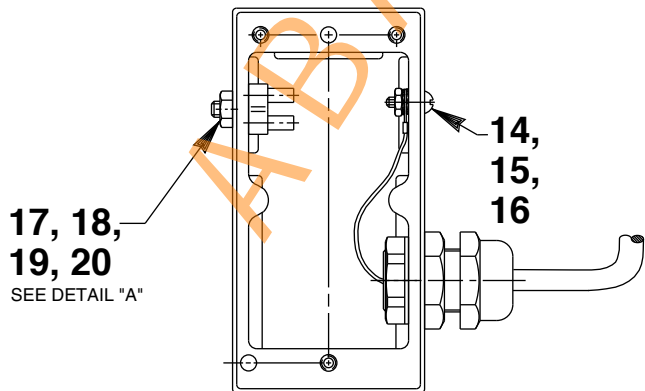
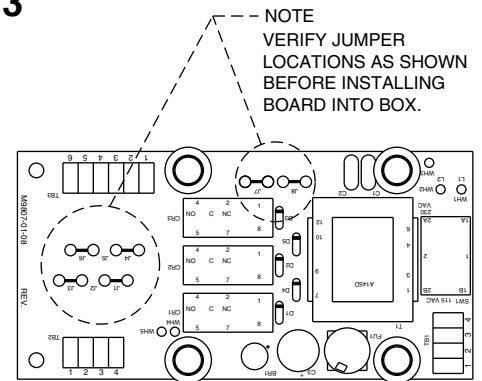
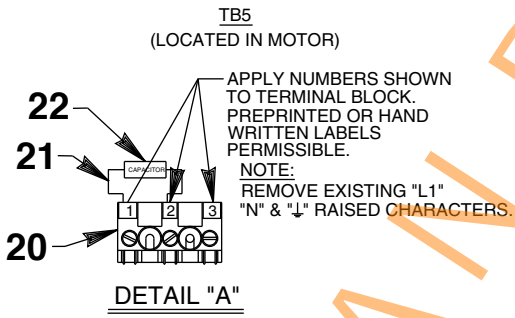

Item No.	Part No.	No. Req'd	Description
1	351588	1	Mounting Plate
2	251845	2	2 pole Center Jumper
3	360001	1	Relay (120 V.; For 110 V. pumps)
	421663	1	Relay (240 V.; For 220 V. pumps)
4	59036	1	Control Box
5	421898	1	Circuit Board
6	10447	2	Rnd. Hd. Screw (8-32 x 5/16)
7	10196	2	Hex Nut (8-32)
8	421608WH2	1	Mounting Bracket
9	251879	26"	Cable (1.5mm/3 HAR)
10	216680	3	Conduit Locknut
11	216666	3	Strain Relief Bushing
12	251842	1	End Barrier
13	251881	1	Hand Control Assembly (See sheet 9 of 9)
14	12354	1	Rnd. Hd. Screw (10-24 x 5/8)
15	11108	2	Ext. Tooth Washer (.40 x .20)
16	10197	1	Hex Nut (10-24)
17	16099	1	Rnd. Hd. Screw (6-32 x 3/4)
18	15906	1	Ext. Tooth Washer (.31 x /15)
19	10195	1	Hex Nut (6-32)
20	351130	.25	Terminal Block
21	206314	.12'	Electrical Tubing
22	252195	1	Capacitor
23	251840	4	Terminal Block
24	360002-30	1	Circuit Breaker (30 AMP; For 110V. pumps.)
	360002-15	1	Circuit Breaker (15 AMP; For 220V. pumps.)
25	251898	1	CE Electrical Warning Decal
26	350988	1	CE Decal
27	251762	1	Warning Decal
28	251852	7	Marker Card
29	251841	2	Grounding Terminal Block
30	12409	4	Rnd. Hd. Screw (8-32 x 5/8)
31	252387	1	Strain Relief Bushing
32	252253	4	Pan Hd. Screw (8-32 x 3/8)
33	252241	8'	Cable (4.0mm/3 HAR)



# MOTOR CONTROL ASSEMBLY FOR PE552S-E110 & PE552S-E220

To Parts List

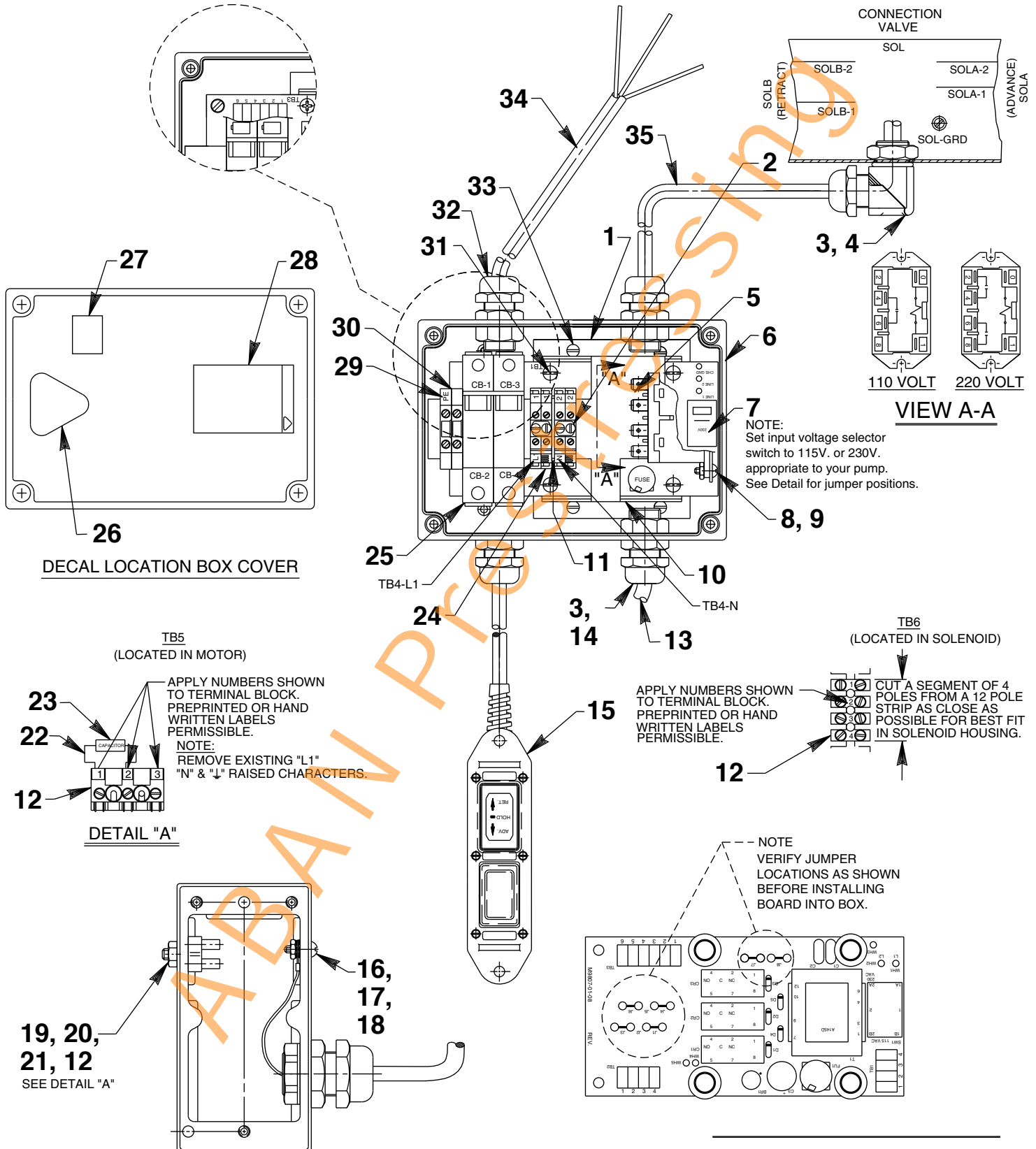

**NOTE:**  
Set input voltage selector switch to 115V. or 230V. appropriate to your pump. See Detail for jumper positions.

**NOTE:**  
REMOVE EXISTING "L1" "N" & "L" RAISED CHARACTERS.

**NOTE:**  
CUT A SEGMENT OF 4 POLES FROM A 12 POLE STRIP AS CLOSE AS POSSIBLE FOR BEST FIT IN SOLENOID HOUSING.

**NOTE:**  
VERIFY JUMPER LOCATIONS AS SHOWN BEFORE INSTALLING BOARD INTO BOX.

19, 20,  
21, 12  
SEE DETAIL "A"

Item No.	Part No.	No. Req'd	Description
1	351588	1	Mounting Plate
2	251845	2	2 pole Center Jumper
3	216680	5	Conduit Locknut
4	216667	1	Strain Relief Bushing
5	360001	1	Relay (120 V.; For 110 V. pumps)
	421663	1	Relay (240 V.; For 220 V. pumps)
6	59036	1	Control Box
7	421898	1	Circuit Board
8	10447	2	Rnd. Hd. Screw (8-32 x 5/16)
9	10196	2	Hex Nut (8-32)
10	421608WH2	1	Mounting Bracket
11	251842	1	End Barrier
12	351130	.60	Terminal Block
13	251879	26"	Cable (1.5mm/3 HAR)
14	216666	4	Strain Relief Bushing
15	252508	1	Hand Control Assembly (See back sheet 9 of 9)
16	12354	1	Rnd. Hd. Screw (10-24 x 5/8)
17	11108	2	Ext. Tooth Washer (.40 x .20)
18	10197	1	Hex Nut (10-24)
19	16099	1	Rnd. Hd. Screw (6-32 x 3/4)
20	15906	1	Ext. Tooth Washer (.31 x /15)
21	10195	1	Hex Nut (6-32)
22	206314	.12'	Electrical Tubing
23	252195	1	Capacitor
24	251840	4	Terminal Block
25	360002-30	1	Circuit Breaker (30 AMP; For 110V. pumps.)
	360002-15	1	Circuit Breaker (15 AMP; For 220V. pumps.)
26	251898	1	CE Electrical Warning Decal
27	350988	1	CE Decal
28	251762	1	Warning Decal
29	251852	7	Marker Card
30	251841	2	Grounding Terminal Block
31	12409	4	Rnd. Hd. Screw (8-32 x 5/8)
32	252387	1	Strain Relief Bushing
33	252253	4	Pan Hd. Screw (8-32 x 3/8)
34	252241	8'	Cable (4.0mm/3 HAR)
35	251864	28"	Cable (1.5mm/3 HAR)



Note: Shaded areas reflect last revision(s) made to this form.

# MOTOR CONTROL ASSEMBLY FOR PE554S-E110 & PE554S-E220

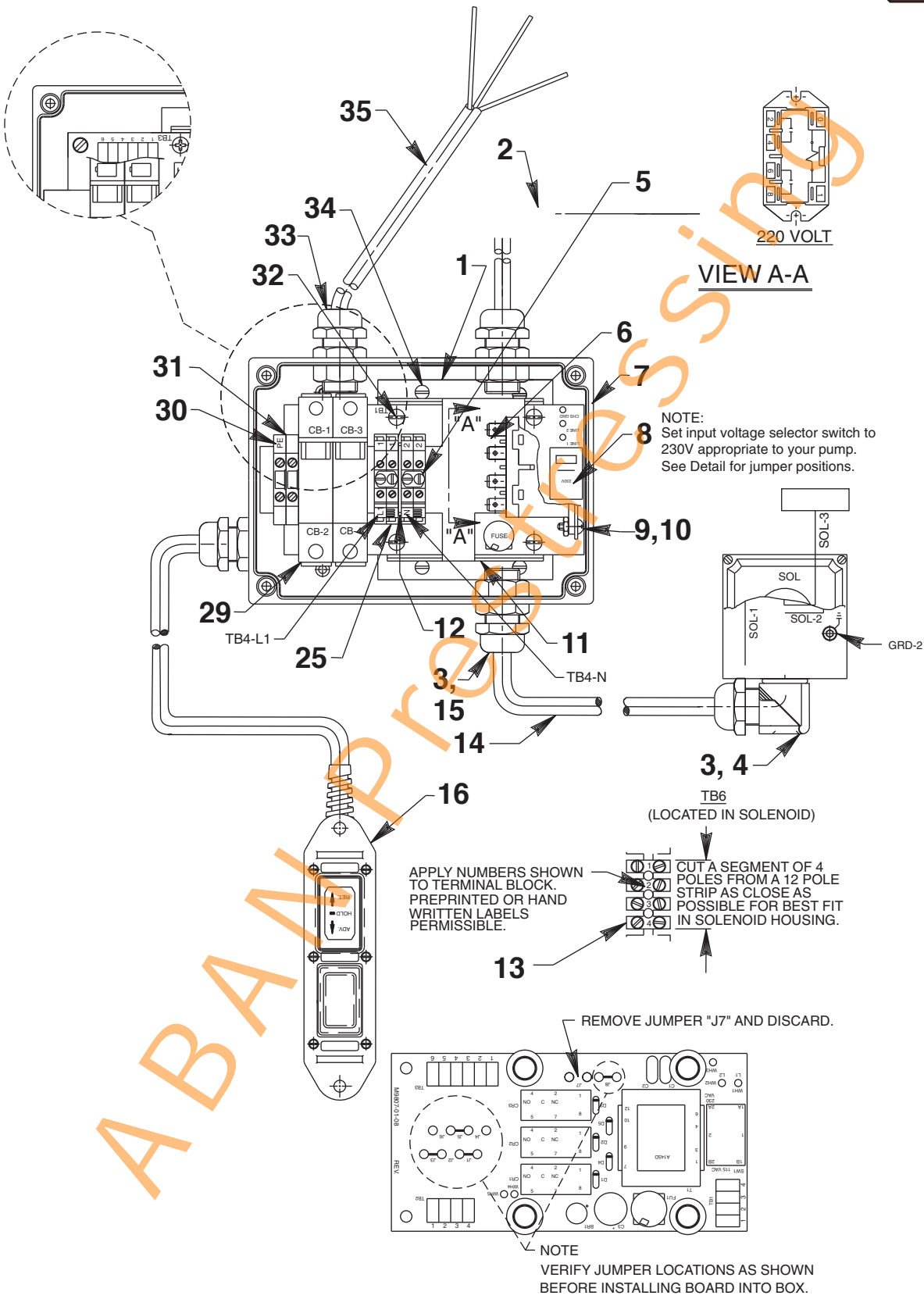

Item No.	Part No.	No. Req'd	Description
1	351588	1	Mounting Plate
2	251879	33"	Cable (1.5mm/3 HAR)
3	216667	1	Strain Relief Bushing
4	216666	4	Strain Relief Bushing
5	251845	2	2 pole Center Jumper
6	360001	1	Relay (120 V.; For 110 V. pumps)
	421663	1	Relay (240 V.; For 220 V. pumps)
7	59036	1	Control Box
8	421898	1	Circuit Board
9	10447	2	Rnd. Hd. Screw (8-32 x 5/16)
10	10196	2	Hex Nut (8-32)
11	421608WH2	1	Mounting Bracket
12	251842	1	End Barrier
13	351130	.50	Terminal Block
14	251879	26"	Cable (1.5mm/3 HAR)
15	216680	5	Conduit Locknut
16	252508	1	Hand Control Assembly (See back sheet 9 of 9)
17	12354	1	Rnd. Hd. Screw (10-24 x 5/8)
18	11108	2	Ext. Tooth Washer (.40 x .20)
19	10197	1	Hex Nut (10-24)
20	251474-1	1	Rnd. Hd. Screw (6-32 x 1")
21	15906	1	Ext. Tooth Washer (.31 x .15)
22	10195	1	Hex Nut (6-32)
23	252195	1	Capacitor
24	206314	.12'	Electrical Tubing
25	251840	4	Terminal Block
26	251898	1	CE Electrical Warning Decal
27	350988	1	CE Decal
28	251762	1	Warning Decal
29	360002-30	1	Circuit Breaker (30 AMP; For 110V. pumps.)
	360002-15	1	Circuit Breaker (15 AMP; For 220V. pumps.)
30	251852	7	Marker Card
31	251841	2	Grounding Terminal Block
32	12409	4	Rnd. Hd. Screw (8-32 x 5/8)
33	252387	1	Strain Relief Bushing
34	252253	4	Pan Hd. Screw (8-32 x 3/8)
35	252241	8'	Cable (4.0mm/3 HAR)





## REMOTE CONTROL HAND SWITCH ASSEMBLY NO. 251881

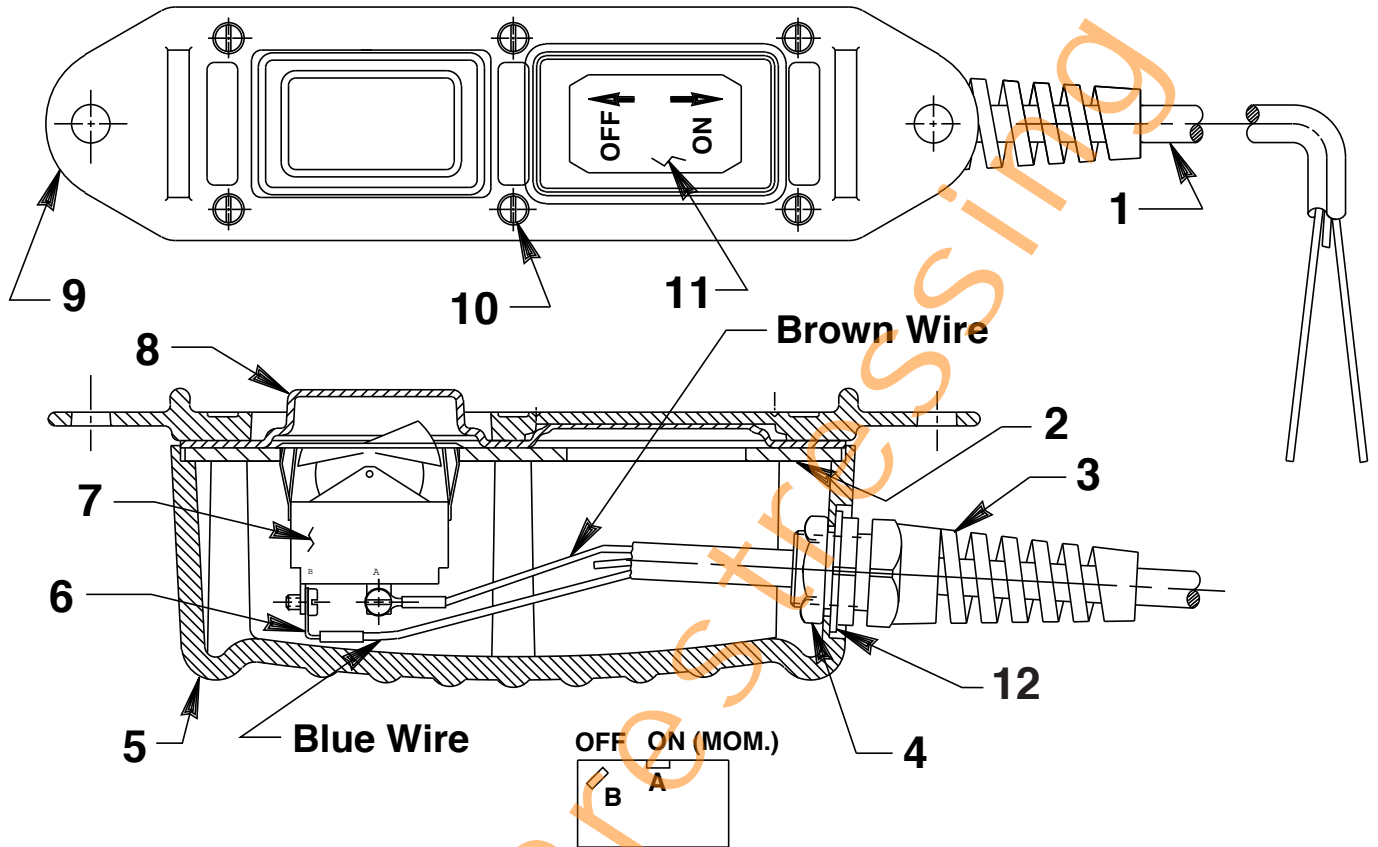

Item No.	Part No.	No. Req'd	Description
1	251879	10 ft.	Electrical Cable (14/3)
2	420050-3	1	Switch Mounting Plate
3	251818	1	Strain Relief Connector
4	251802	1	Locknut (3/4-16 UNF)
5	420050-4	1	Switch Housing
6	10525	2	Ring Terminal
7	16772	1	Rocker Switch
8	420050-2	1	Gasket
9	420050-1	1	Cover
10	250248	6	Screw (4-24 x 3/4 Lg.)
11	202763	1	Decal
12	253607	1	Rubber Gasket

## REMOTE CONTROL HAND SWITCH ASSEMBLY NO. 252508

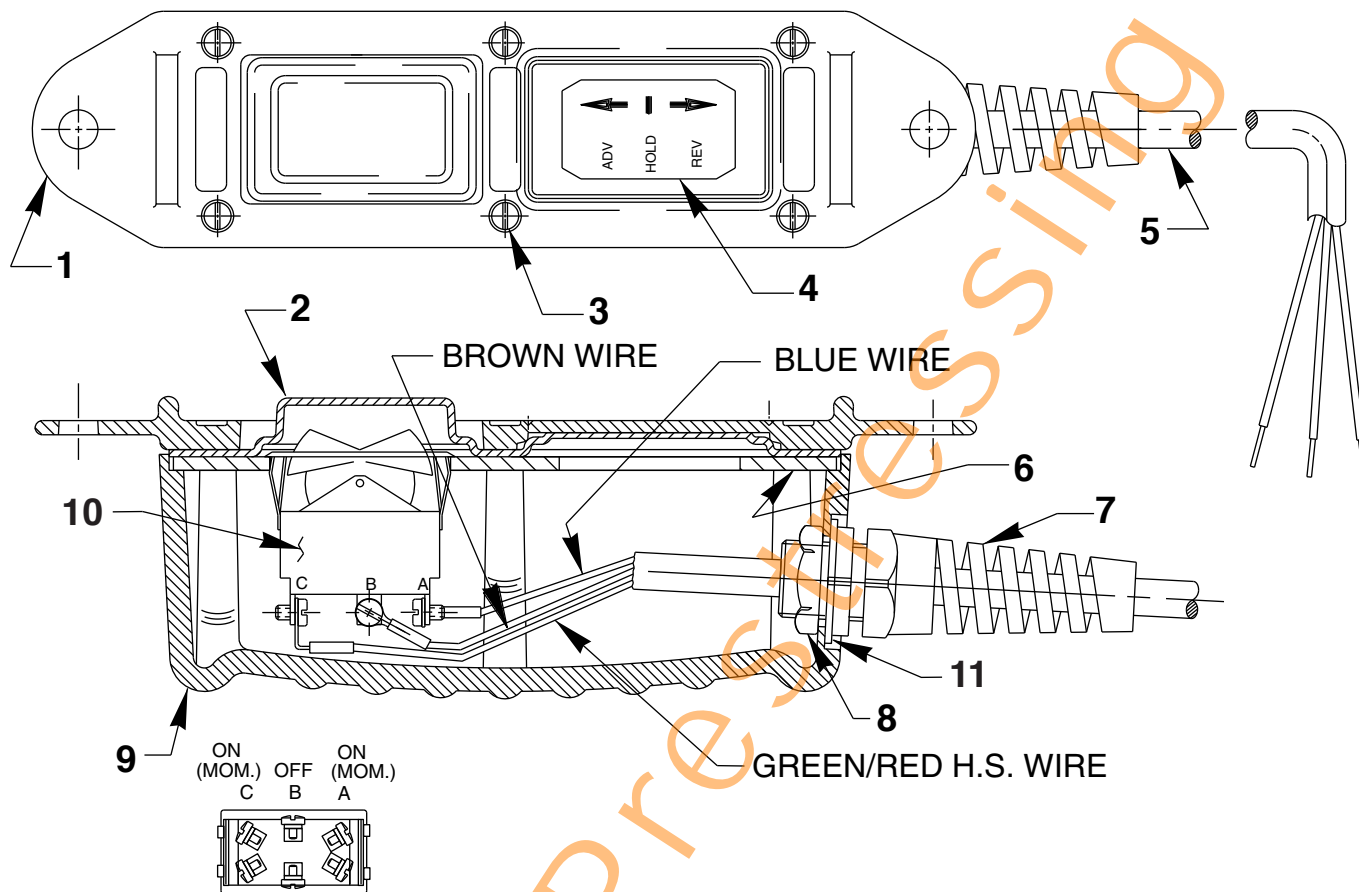

Item No.	Part No.	No. Req'd	Description
1	420050-1	1	Plastic Cover
2	420050-2	1	Gasket
3	250248	6	Screw (4-24 X 3/4 Lg.)
4	202776	1	Decal
5	251879	10 ft.	Electrical Cable (1.5 MM/3 HAR)
6	420050-3	1	Switch Mounting Plate
7	251818	1	Strain Relief Bushing
8	251802	1	Locknut (Torque to 30/35 in. lbs.)
9	420050-4	1	Switch Housing
10	16774	1	Rocker Switch
11	253607	1	Rubber Gasket