

# POST- TENSIONED CONCRETE FLOORS IN MULTI-STOREY BUILDINGS

An introduction to the development, benefits, design and construction of in-situ prestressed suspended floors

A M Stevenson BSc(Hons), CEng, MICE, MStructE

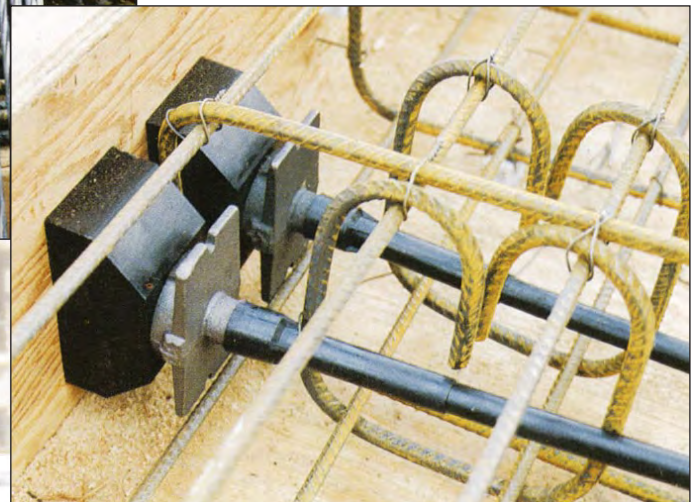
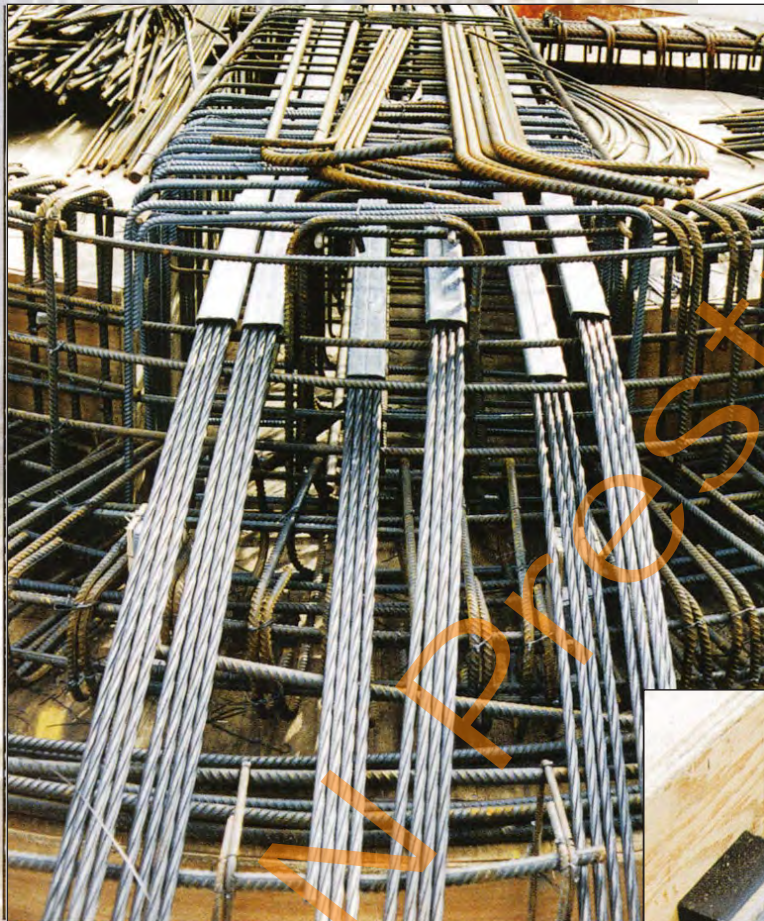

## FOREWORD

This publication was commissioned by the Reinforced Concrete Council, which was set up to promote better knowledge and understanding of reinforced concrete design and building technology.

Its members are Co-Steel Sheerness plc and Allied Steel & Wire, representing the major suppliers of reinforcing steel in the UK, and the British Cement Association, representing the major manufacturers of Portland cement in the UK.

The author, Mark Stevenson, is an Associate with Gifford and Partners.

## ACKNOWLEDGEMENTS

The Reinforced Concrete Council and the author are grateful to Sami Khan, Peter Mathew, David Ramsey and all those who provided comments on the draft of this publication, and for the photographic material supplied by PSC Freyssinet Limited. Thanks are also extended to Alan Tovev of Tecnicom for his work in co-ordinating this publication.

## ABOUT THIS PUBLICATION

This publication aims to de-mystify the techniques of post-tensioned concrete floor construction in multi-storey buildings, whilst looking at the economics and practicability of construction. It is intended for two broad categories of reader.

Firstly, it presents an introduction to the benefits, constraints, principles and techniques for non-technical professionals. These people will wish to understand the broad issues of an essentially simple technique with which they may not be entirely familiar, without being swamped by equations. Sections 1 and 3 provide the briefest executive overview, whilst reading Sections 1 to 4 plus 7 will give a broader picture.

Secondly, it can be used as a more technical review for those who, in addition to the above issues, wish to explore further the principles of design and construction. In this case all sections should prove useful.

This publication is not intended to be a full technical reference book for design, but it does address many of the issues often omitted from such works.

97.347

First published 1994

ISBN 0 7210 1481 X

Price Group D

© British Cement Association 1994

Published by the British Cement Association on behalf of the industry sponsors of the Reinforced Concrete Council.

British Cement Association

Century House, Telford Avenue

Crowthorne, Berkshire RG11 6YS

Tel (0344) 762676 Fax (0344) 761214



# CONTENTS

<b>1</b>	<b>INTRODUCTION</b>	<b>2</b>
<b>2</b>	<b>DEVELOPMENT AND APPLICATIONS</b>	<b>2</b>
	Principles of prestressing	2
	Development of post-tensioning	3
<b>3</b>	<b>BENEFITS OF POST-TENSIONED CONSTRUCTION</b>	<b>6</b>
<b>4</b>	<b>RANGE AND SELECTION OF FLOORS</b>	<b>7</b>
	Forms of construction	7
	Typical properties	8
	Selection criteria	8
	Comparison with other floor types	9
<b>5</b>	<b>DESIGN CONSIDERATIONS</b>	<b>10</b>
	Theory and design	10
	Restraint	
	Holes	13
<b>6</b>	<b>CONSTRUCTION</b>	<b>14</b>
	Aspects of construction	13
<b>7</b>	<b>DEMOLITION AND STRUCTURAL ALTERATIONS</b>	<b>17</b>
	Demolition	17
	Structural alterations	17
<b>8</b>	<b>REFERENCES</b>	<b>19</b>

# 1 INTRODUCTION

Over the last 20 years, many buildings with post-tensioned floor slabs have been successfully constructed in the USA, South East Asia, Australia and the rest of Europe, yet it took the construction boom of the late 1980s, with corresponding increases in both steelwork prices and delivery times, to generate significant interest in post-tensioned floor construction in the UK.

The purpose of this publication is to widen the understanding of post-tensioned floor construction and show the considerable benefits and opportunities it offers to both the developer and designer. These include:

- Rapid construction
- Economy
- Maximum design flexibility
- Minimum storey heights
- Minimum number of columns
- Optimum clear spans
- Joint-free, crack-free construction
- Controlled deflections.

Post-tensioned floors may be totally of in-situ concrete or a hybrid of in-situ and precast concrete. Either may be prestressed or a combination of prestressed and reinforced. They can be designed as two-way spanning flat slabs, one-way spanning ribbed slabs, or as banded beam and slab construction. Flat slabs are supported, without the use of beams, by columns with or without column heads. They may be solid or may have recesses formed in the soffit to create a series of ribs running in two directions (waffle or coffered slab). All these post-tensioned floors are further described in Section 4, and shown in Figures 4.1 to 4.4.

This publication also aims to dispel the myths about post-tensioned concrete slabs by showing that:

- They are not 'unexploded bombs'
- The floors can be demolished safely
- Local failure does not lead to total collapse
- Holes can be cut in slabs at a later date
- The design is not necessarily complicated
- They are compatible with fast-track construction
- They do not require the use of high-strength concrete
- The formwork does not carry any of the prestressing forces.

Post-tensioned concrete can satisfy all of the above requirements, and for this reason it is commonly used throughout most of the developed world.

There are a number of publications that highlight the suitability of in-situ reinforced concrete frames for both economy and speed of construction in high-rise buildings<sup>2,3</sup>. The use of post-tensioned concrete slabs complements such a frame and helps maximise the benefits from both economy and speed. An example of a prestigious city centre development using this form of construction is Exchange Tower in Docklands<sup>4</sup>.

Engineers have a responsibility to their clients to consider all available construction methods. Post-tensioned concrete will not always be the most suitable, but it should at least

be properly evaluated while considering other more familiar techniques.

# DEVELOPMENT AND APPLICATIONS

## 2

The practice of prestressing can be traced back as far as 440 BC, when the Greeks reduced bending stresses and tensions in the hulls of their fighting galleys by prestressing them with tensioned ropes.

A further example, and one which demonstrates the simplicity of prestressing, is a traditional timber barrel where the tension in the steel hoops effectively compresses the staves together to enhance both strength and stability.

One of the simplest examples of prestressing is that of trying to lift a row of books as illustrated in Figure 2. 1. To lift the books it is necessary to push them together, ie to apply a pre-compression to the row. This increases the resistance to slip between the books so that they can be lifted.

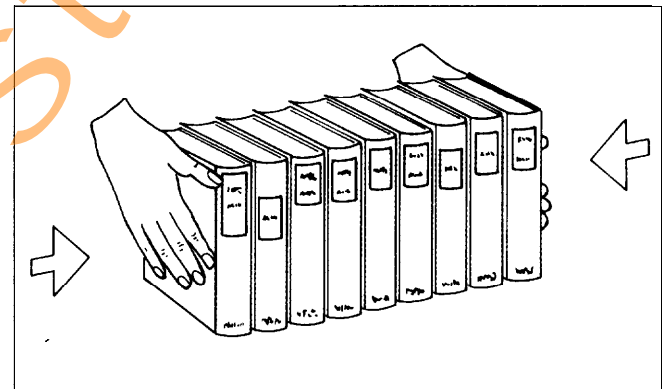

Figure 2.1 Lifting a row of books

This example also demonstrates one of the common principles shared by most applications of prestressing. There is generally a deficiency which can be offset by an efficiency which can be easily exploited. In the case of the books there is no grip between the books but the books can withstand compression loads which can be easily applied.

A simple definition of prestressing, which relates well to the example of the books, is:

*'The act of applying forces to a structure, other than the loads the structure is designed to carry, in order to enhance the structure's ability to carry those loads'.*

## Principles of prestressing

Concrete has a low tensile strength but is strong in compression: by pre-compressing a concrete element, so that when flexing under applied loads it still remains in compression, a more efficient design of the structure can be achieved. The basic principles of prestressed concrete are given in 2.2, and further information on the

development of prestressing and prestressing materials is given in Reference 5.

Under an applied load, a prestressed beam will bend, reducing the built-in compression stresses; when the load is removed, the prestressing force causes the beam to return to its original condition, illustrating the resilience of prestressed concrete. Furthermore, tests have shown that a virtually unlimited number of such reversals of the loading can be carried out without affecting the beam's ability to carry its working load or impairing its ultimate load capacity. In other words prestressing endows the beam with a high degree of resistance to fatigue.

It is indicated in *Figure 2.2* that if, at working load, the tensile stresses due to load do not exceed the prestress, the concrete will not crack in the tension zone but, if the working load is exceeded and the tensile stresses overcome the prestress, cracks will appear. However, even after a beam has been loaded to beyond its working load, and well towards its ultimate capacity, removal of the load results in complete closing of the cracks and they do not reappear under working load.

There are two methods of applying prestress to a concrete member. These are:

- 1) By pretensioning - where the concrete is placed around previously stressed tendons. As the concrete hardens, it grips the stressed tendons and when it has obtained sufficient strength the tendons are released, thus transferring the forces to the concrete. Considerable force is required to stress the tendons, so pretensioning is principally used for precast concrete where the forces can be restrained by fixed abutments located at each end of the stressing bed, or carried by specially stiffened moulds.
- 2) By post-tensioning - where the concrete is placed around sheaths or ducts containing unstressed tendons. Once the concrete has gained sufficient strength the tendons are stressed against the concrete and locked off by special anchor grips. In this system, which is the one employed for the floors described in this publication, all tendon forces are transmitted directly to the concrete. Since no stresses are applied to the formwork, this enables conventional formwork to be used.

## Development of post-tensioning

The invention of prestressed concrete is often accredited to Eugene Freyssinet who developed the first practical post-tensioning system in 1939. The majority of the early applications were in the design of bridge structures. The systems were developed around the use of multi-wire tendons located in large ducts cast into the concrete section, and fixed at each end by anchorages. They were stressed by jacking from either one or both ends, and then the tendons were grouted within the duct. This is generally referred to as a bonded system as the grouting bonds the tendon along the length of the section.

The bonding is similar to the way in which bars are bonded in reinforced concrete. After grouting is complete there is

Prestressed concrete can most easily be defined as precompressed concrete. This means that a compressive stress is put into a concrete member before it begins its working life, and is positioned to be in areas where tensile stresses would otherwise develop under working load. Why are we concerned with tensile stresses? For the simple reason that, although concrete is strong in compression, it is weak in tension.

Consider a beam of plain concrete carrying a load.

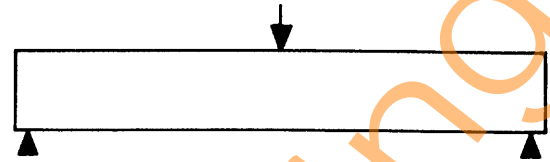

As the load increases, the beam deflects slightly and then falls abruptly. Under load, the stresses in the beam will be compressive in the top, but tensile in the bottom. We can expect the beam to crack at the bottom and break, even with a relatively small load, because of concrete's low tensile strength. There are two ways of countering this low tensile strength by using reinforcement or by prestressing.

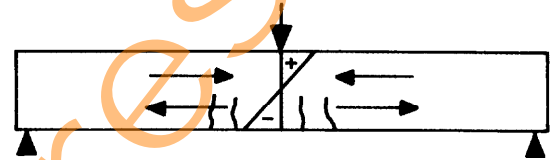

In reinforced concrete, reinforcement in the form of steel bars is placed in areas where tensile stresses will develop under load. The reinforcement absorbs all the tension and, by limiting the stress in this reinforcement, the cracking of the concrete is kept within acceptable limits.

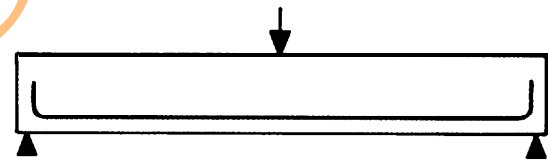

In prestressed concrete, compressive stresses introduced into areas where tensile stresses develop under load will resist or annul these tensile stresses. So the concrete now behaves as if it had a high tensile strength of its own and, provided the tensile stresses do not exceed the precompression stresses, cracking cannot occur in the bottom of the beam. The precompression stresses can also be designed to overcome the diagonal tension stresses. The normal procedure is to design to eliminate cracking at working loads.

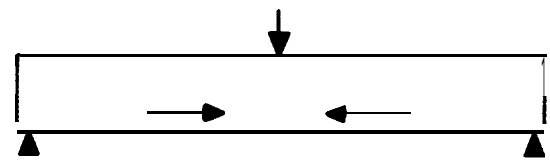

However, bending is only one of the conditions involved: there is also shear. Vertical and horizontal shear forces are set up within a beam and these will cause diagonal tension and diagonal compression stresses of equal intensity. As concrete is weak in tension, cracks in a reinforced concrete beam will occur where these diagonal tension stresses are high, usually near the support. In prestressed concrete, the precompression stresses can also be designed to overcome these tension stresses.

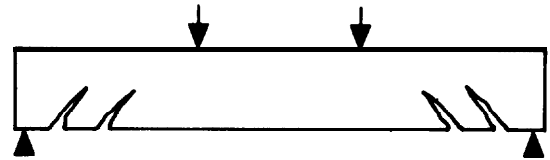

**Figure 2.2** Principles of prestressed concrete

no longer any reliance on the anchorage to transfer the precompression into the section. Another common application is in segmental construction (Figure 2.3) where precast concrete bridge sections are prestressed together with steel cables or bars, developing the simple idea of compressing the row of books.



Figure 2.3 Segmental construction in bridge decks

Applications in building have always existed in the design of large span beams supporting heavy loadings, but the systems were not suitable for prestressing floor slabs, which cannot accommodate either the large ducts or anchorages.

The more recent development of post-tensioning specifically for in-situ floor slab construction has resulted in two systems: (1) bonded construction and (2) unbonded construction.



Figure 2.4 Bonded tendons in beam

With the bonded system (Figure 2.4) the prestressing tendons run through small continuous flattened ducts which are grouted after the tendons are stressed. The system has been used successfully in general floor slab construction and is often used for specialist applications. Cost-effective designs can be achieved by this system, the principal features of which are given below.

The most efficient prestress design is when the prestressing tendon is positioned eccentrically in the concrete section on a curved profile or deflected from a straight line. The size of the duct used in a bonded system and the minimum cover that must be provided may control the maximum eccentricity that can be achieved.

The ducts are formed from spirally-wound or seam-folded galvanised metal strip. The limit on the curvature

or profile that can be achieved with the prestressing tendons is dependent on the flexibility of the ducts.

The ducts have to be grouted after stressing, which introduces a further trade into the construction process.

To offset these features in floor slab applications, prestressing using unbonded systems (Figure 2.5) was developed in the USA in the 1960s.



Figure 2.5 Unbonded tendons in a floor slab

From the early days of prestressed concrete bridge design, the benefits of not bonding the tendons to the concrete structure have been appreciated, and bridges have been constructed with unbonded tendons running both internally and externally to the structure. Systems for use on bridge structures were again based on large multi-strand tendons. The main benefits to the bridge designer were that tendons were replaceable should corrosion occur and, if external, could be inspected as part of routine maintenance.

In an unbonded system the tendon is not grouted and remains free to move independently of the concrete. This has no effect on the serviceability design or performance of a structure under normal working conditions. It does, however, change both the design theory and structural performance at the ultimate limit state, which is preceded by larger deflections with fewer, but larger, associated cracks than with an equivalent bonded system. Thus, with an unbonded system there are obvious visual indications that something is wrong well before failure occurs.

The economic advantages of an unbonded system in floor slab construction were identified, and systems were developed in the 1960s specifically for this application. Tendons used today are typically either 12.9 mm or 15.7 mm strands, coated in grease, within a protective sheath. They are cast into the concrete slab with small (typically 130 mm x 70 mm) anchorages fixed to each end. After concreting, and when the concrete has obtained a specified compressive strength, the tendon is stressed very simply using a small hand-held jack, completing the post-tensioning operation.

The particular features of an unbonded system are:

Tendons can be located close to the surface of the concrete to maximise the eccentricity (Figure 2.6).

Tendons are flexible and can be easily fixed to different profiles. They can be displaced locally around holes, (Figure 2.7), and to accommodate changes in slab shape (Figure 2.8).



The stressing operation is simple, and with no grouting, is suited to rapid construction methods.

The use of unbonded tendons permits an effective and competitive multi-storey construction to be carried out in post-tensioned concrete.

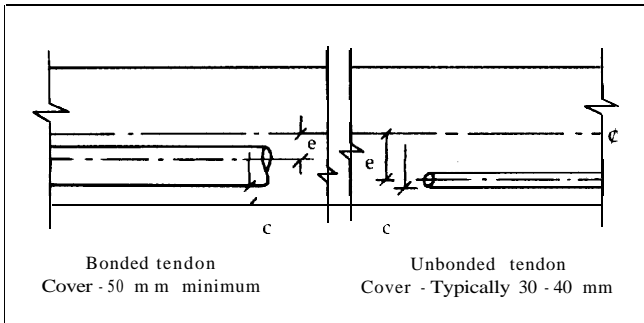

Figure 2.6 Tendon eccentricity

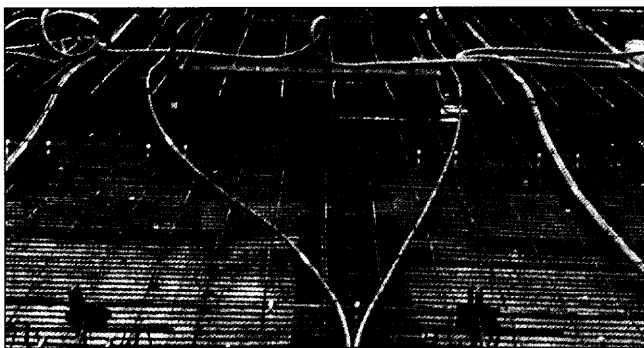

Figure 2.7 Flexibility of tendons allows displacement around holes



Figure 2.8 Tendons displaced to accommodate changes in slab shape

The bonded and unbonded systems provide a range of post-tensioning methods available to the designer of buildings. In some instances the most economical design can be achieved with a post-tensioned floor slab, using unbonded tendons, supported on long-span post-tensioned beams with bonded tendons. Post-tensioned floor construction can also be combined with conventional reinforced concrete slabs to extend the range of concrete floor options.

The benefits of post-tensioned construction for floors were quickly appreciated in the USA and many other parts of the developed world, where its use in multi-storey construction is widespread. Systems have been available

in the UK since the 1960s and some interest was generated during the early 1970s. However, it took the construction boom of the 1980s to generate significant interest in post-tensioning of floors and the many schemes now completed have demonstrated to clients, architects and engineers the many advantages of the system when used in multi-storey construction. Figure 2.9(a) to (e) shows examples of buildings using post-tensioned floors.

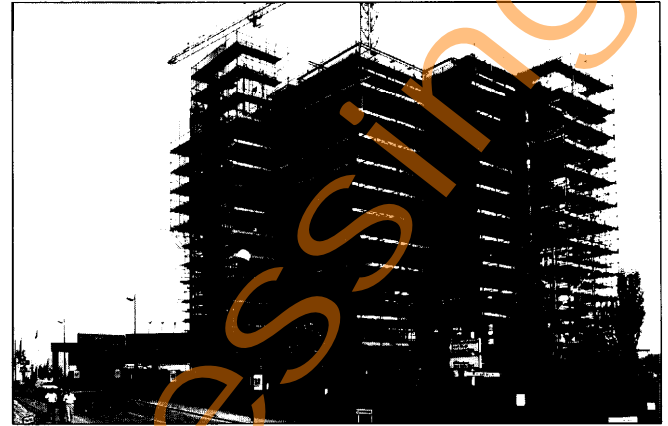

Figure 2.9(a) The Pavilion, London Docklands: post-tensioned flat slab

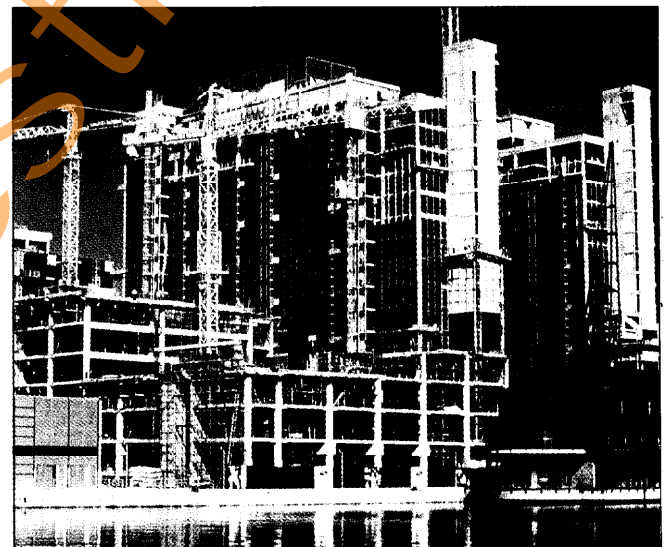

Figure 2.9(b) Exchange Tower, London Docklands: post-tensioned ribbed slabs

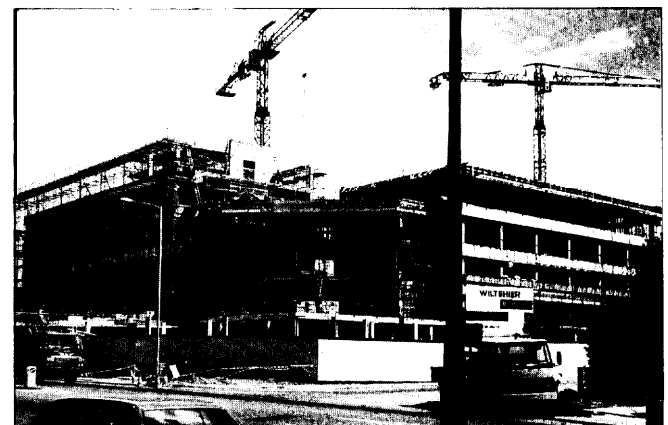

Figure 2.9(c) Office block, Hemel Hempstead: post-tensioned construction

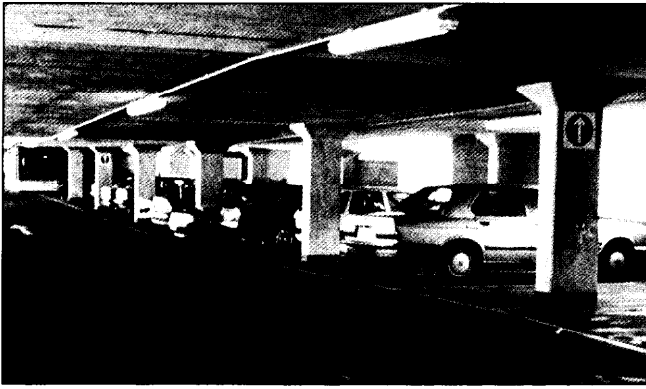

Figure 2.9(d) Car park, Fleet: post-tensioned flat slab



Figure 2.9(e) Windmill Hill, Swindon: post-tensioned waffle slab

### 3

## BENEFITS OF POST-TENSIONED CONSTRUCTION

The following are just a few of the many benefits to be gained from using post-tensioned floor construction.

Long spans reduce the number of columns and foundations, providing increased flexibility for internal planning, and maximising the available letting space of a floor.

**Minimum floor thickness** maximises the ceiling zone available for horizontal services, minimises the selfweight and foundation loads, and keeps down the overall height of the building.

Minimum storey height is achieved, as the need for deep downstands is reduced, and slab thicknesses are kept to a minimum. As a result, the storey height of a concrete building can be less than that of a steel-framed building by as much as 300 mm per floor. This can give an extra storey in a ten-storey building. Alternatively, it minimises the exterior surface area to be enclosed, as well as the vertical runs of mechanical and electrical systems. The reduced building volume (Figure 3.1) will save on cladding costs and may reduce running costs of HVAC equipment.

**Deflection of the slab can be controlled** enabling longer spans to be constructed with a minimum depth of construction.

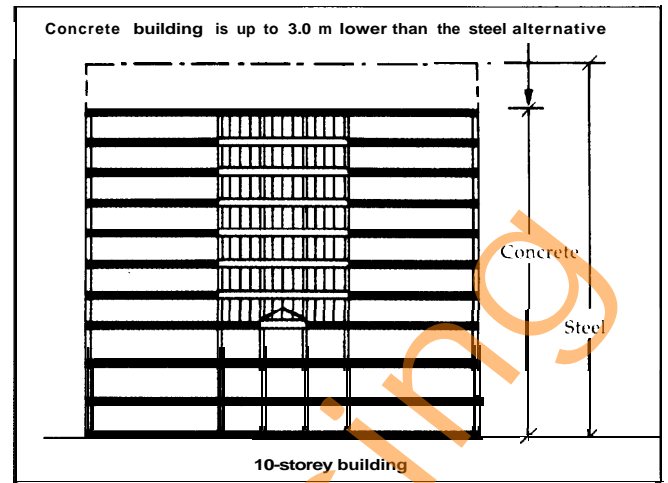

Figure 3.2 Effect of post-tensioned construction on building height and volume

**Crack-free construction** is provided by designing the whole slab to be in compression under normal working loads. Appropriate details may also be incorporated to reduce the effects of restraint, which may otherwise lead to cracking (see Restraint in Section 5). This crack-free construction is often exploited in car parks with concrete surfaces exposed to an aggressive environment.

**Large area pours** should be adopted on all concrete floors in order to reduce the number of pours and increase construction speed and efficiency (Figure 3.2). With prestressed floors, when the concrete has reached a strength of typically 12.5 N/mm<sup>2</sup>, part of the prestressing force can be applied to control shrinkage cracking and thus further aid larger area pours.

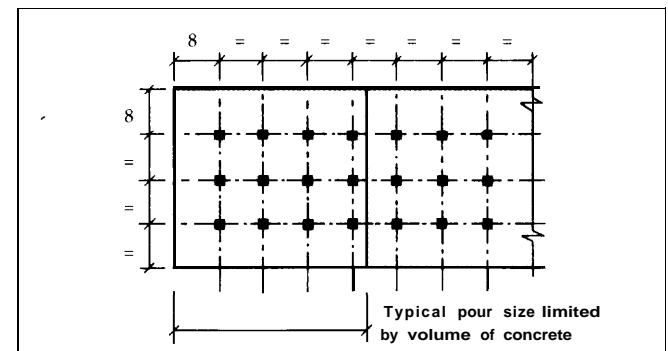

Figure 3.2 Large area pours for increased efficiency

**Rapid construction** is readily achieved in multi-storey buildings as prestressing leads to less congested slab construction (Figure 3.3). Prefabrication of tendons reduces fixing time and early stressing enables forms to be stripped quickly and moved to the next floor.

**Flexibility of layout** can be achieved as the design methods can cope with irregular grids, and tendons can easily be deflected horizontally to suit the building's geometry or to allow for openings in slabs.

Future flexibility is provided as knockout zones can be identified for future service penetrations. Tried and tested methods are available to enable large openings for stairs, escalators and other features to be formed subsequently (see Section 7).



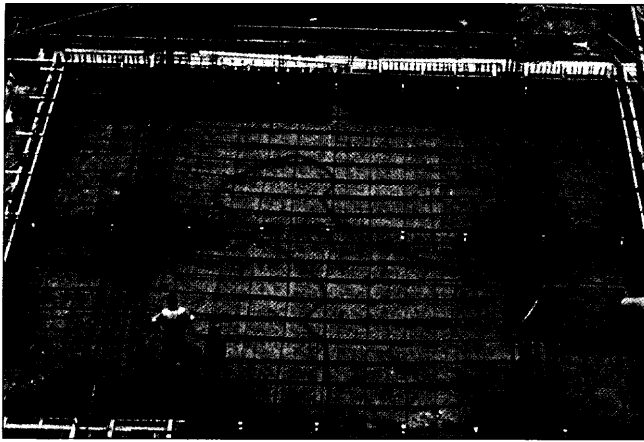

Figure 3.3 Minimising the amount of site-fixed reinforcement speeds up construction

## 4

# RANGE AND SELECTION OF FLOORS

## Forms of construction

For most multi-storey buildings there is a suitable concrete framing system. For spans greater than 6.0 m, post-tensioned slabs start to become cost-effective, and can be used alone or combined with reinforced concrete to provide a complementary range of in-situ concrete floor options. The three main forms of construction are given below.

### Solid flat slab

Spans: 6 m to 13 m

An efficient post-tensioned design can be achieved with a solid flat slab (Figure 4.1), which is ideally suited to multi-storey construction where there is a regular column grid. These are sometimes referred to as flat plate slabs. The benefits of a solid flat slab are the flush soffit and minimum construction depth, which are suited to rapid construction methods. These provide the maximum flexibility for horizontal service distribution and keep slab weight low and building height down to a minimum.

The depth of a flat slab is usually controlled by deflection requirements or by the punching shear capacity around the column. Post-tensioning improves control of deflections and enhances shear capacity. The latter can be increased further by introducing steel shearheads within the slab depth (Figure 4.1 (a)), column heads (Figure 4.1 (b)), or drop panels (Figure 4.1 (c)).

### Beam and slab

Spans: beams 8 m to 20 m, slabs 7 to 10 m

In modern construction, where there is generally a requirement to minimise depth, the use of wide, shallow band beams (Figure 4.2) is common. The beams, which are either reinforced or post-tensioned, support the one-way spanning slab and transfer loads to the columns.

Structural steel shearheads or reinforcement assemblies can be used for increased shear capacity

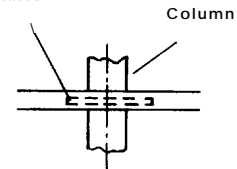

No drop or column head

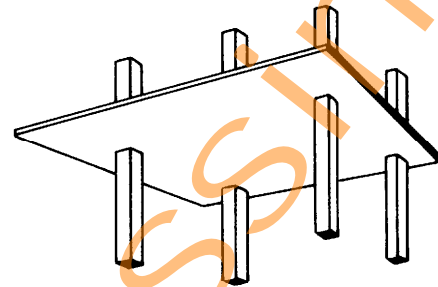

(a) Solid flat slab

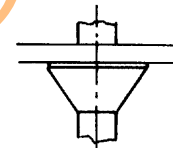

Column head no drop

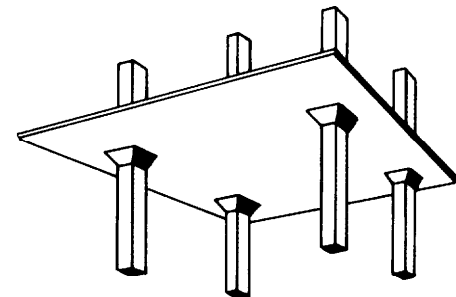

(b) Solid flat slab with column heads

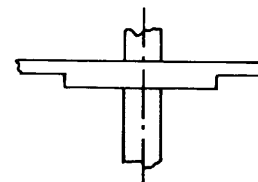

Drop panel

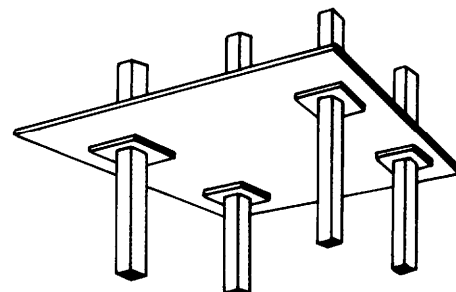

(c) Solid flat slab with drop panel

Figure 4.1 Forms of solid flat slab

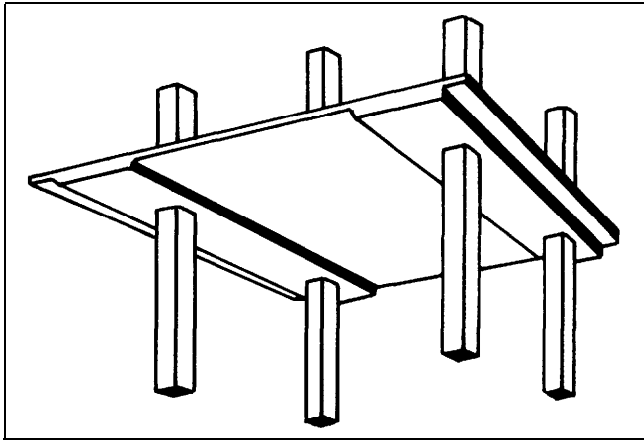

Figure 4.2 Band beam and slab

### Ribbed slab

Spans: 8 m to 18 m

For longer spans the weight of a solid slab adds to both the frame and foundation costs. By using a ribbed slab, (Figure 4.3) which reduces the selfweight, large spans can be economically constructed. The one-way spanning ribbed slab provides a very adaptable structure able to accommodate openings. As with beam and slab floors, the ribs can either span between band beams formed within the depth of the slab or between more traditional downstand beams. For long two-way spans, waffle slabs (Figure 4.4) give a very material-efficient option capable of supporting high loads.

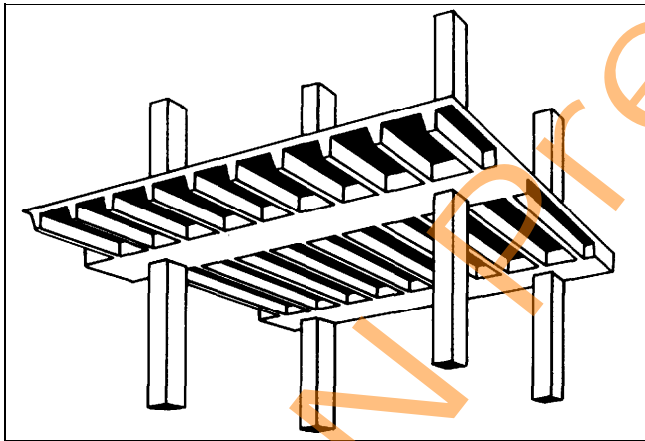

Figure 4.3 Ribbed slab

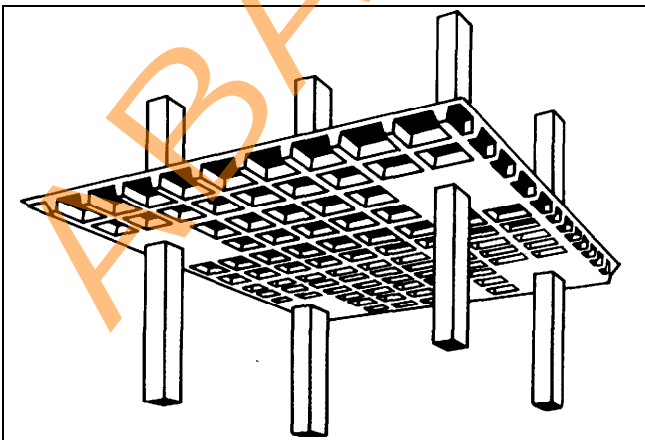

Figure 4.4 Waffle slab

## Typical properties

The typical ranges of spans for the various forms of construction are given in Figure 4.5 and their corresponding slab and beam depths in Table 4.1. Table 4.2 gives the corresponding material quantities for the more common arrangements. The depths and quantities given are for an imposed loading of 5 kN/m<sup>2</sup>, but can be reduced when this is lowered. They will also depend on such things as number of panels in each direction, fire rating, durability and vibration requirements. Although post-tensioned floors are usually thinner and lighter than reinforced floors, vibration is not normally a problem and is typically catered for by controlling the span/depth ratio.

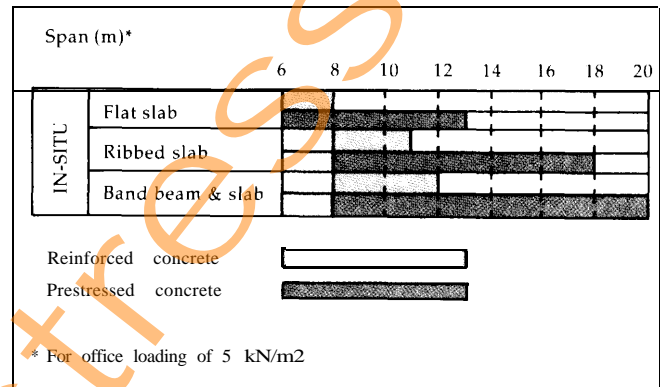

Figure 4.5 Typical economical spans with different types of slab

Table 4.1 Typical slab and beam depths\*

SLAB TYPE	SLAB SPAN m	SLAB DEPTH mm	BEAM DEPTH mm	SPAN/ DEPTH RATIO
Solid flat slab	6.0	200	---	1/30
	8.0	250	---	1/32
Solid flat slab with dropped panels	8.0	225	---	1/36
	12.0	300	---	1/40
One-way slab with band beams	6.0	150	300	1/40/20
	8.0	200	375	1/40/21
	12.0	300	550	1/40/22
One-way slab with narrow beams	6.0	175	375	1/34/16
	8.0	225	500	1/36/16
	12.0	325	750	1/37/16
Ribbed slab	8.0	300	---	1/27
	12.0	450	---	1/27
	15.0	575	---	1/26

\*Based on an imposed loading of 5 kN/m<sup>2</sup>.

## Selection criteria

When faced with selecting the most economic frame for any particular building, it is not just the straight cost of the frame element which is compared. The effect of the frame on the cost of other building provisions is often the governing criterion. The most important of these are the external cladding, flexibility for future use and, in highly serviced buildings, the services distribution both horizontally and vertically through the building.

Table 4.2 Material quantities\*

SLAB TYPE	SLAB SPAN mm	SLAB DEPTH mm	TENDON DENSITY tendons per metre width	REBAR DENSITY kg/m <sup>2</sup>
Flat slab	6.0	200	1.4 †	8.5
	8.0	250	2.3 †	12.0
One-way slab with band beam	6.0	150	3.2	6.5
	8.0	200	3.0	7.5
Ribbed slab**	8.0	300	2.5	10.0
	12.0	450	2.5	13.0
	15.0	575	3.8	17.5

\*Based on an imposed load of 5 kN/m<sup>2</sup>.

The tendon density is based on 15.7 mm diameter super strand with a guaranteed ultimate tensile strength of 265 kN.

The rebar density is based on high yield bar,  $f_y=460$  N/mm<sup>2</sup>.

† Each way    \*\*Quantities per rib depend on rib spacing.

### Distribution of services

The key to the successful design of most buildings is to co-ordinate the design across all disciplines in the team. Of fundamental importance is the co-ordination of services and structure to ensure that clashes with beams, columns, etc do not happen, and that a practical discipline for both primary and secondary service holes is established and adhered to. It is desirable, therefore, to construct a frame which provides the least hindrance to the distribution of services.

The other pressure on the design team is to keep to a minimum the depth of the ceiling void used for distribution, in order to keep down the overall height of the building and to minimise cladding costs.

It can be appreciated that the ideal floor slab to satisfy the above criteria must be the thinnest possible and with a flush soffit, hence the reason that post-tensioned floor construction is so attractive in multi-storey construction.

### Flexibility of use

For office construction, flexibility is mostly concerned with likely future changes in the internal space planning. In many cases these do not substantially affect the structure. Core areas, primary services distribution and other major items usually remain fixed, although some additional holes for minor services may be required subsequently. On the other hand, applications such as retail or health care require a higher degree of flexibility for changes in services, and these should be considered at the design stage.

Regardless of construction type, forming large holes in any existing structure is not straightforward. In post-tensioned design, careful consideration is necessary before breaking out any openings in an existing slab and this is discussed later in Section 7. Smaller holes seldom present problems as they may be readily formed between ribs or grouped tendons. The positions of the tendons can be marked on the slab's soffit to aid identification for future openings (see Section 6).

### Cladding

The depth of the overall floor construction has a direct effect on the cost of the external cladding, which often costs more than the frame. This is particularly relevant in multi-storey construction where a few centimetres saved at each floor can show a significant overall cost saving.

### Comparison with other floor types

Figure 4.6 (a-d) shows a comparison of various floor designs carried out at the scheme stage for a multi-storey hospital structure. The planning grid is 6.6 m square and the floors have been designed for a total imposed load (dead and live) of 5.5 kN/m<sup>2</sup>.

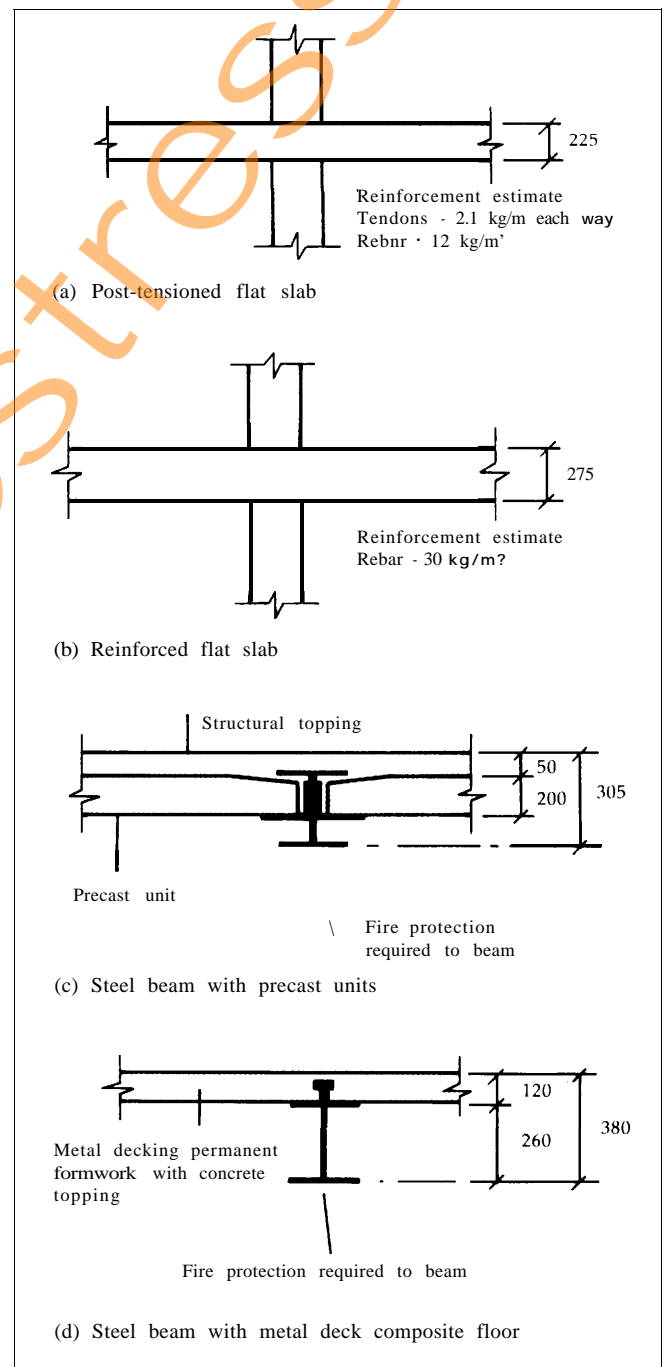



# DESIGN CONSIDERATIONS

## Theory and design

Prestressing methods are now widely available to allow the efficient and economical design of all types of structures. Checks at both serviceability and ultimate limit state are carried out to give the designer a good understanding of the overall structural performance. Recommendations for the design of prestressed concrete are given in BS 8110<sup>(6)</sup>. Design methods for post-tensioned flat slabs are relatively straightforward, and detailed guidance is available in Concrete Society Technical Reports 17<sup>(7)</sup>, 25<sup>(8)</sup> and 43<sup>(9)</sup>.

At the serviceability condition the concrete section is checked at all positions to ensure that both the compressive and tensile stresses lie within acceptable limits. Stresses are checked in the concrete section at the initial condition when the prestress is applied, and at serviceability conditions when calculations are made to determine the deflections for various load combinations.

At the ultimate limit state the pre-compression in the section is ignored and checks are made to ensure that the section has sufficient moment capacity. Shear stresses are also checked at the ultimate limit state in a similar manner to that for reinforced concrete design, although the benefit of the prestress across the shear plane may be taken into account.

In carrying out the above checks, extensive use can be made of computers either to provide accurate models of the structure, taking into account the affect of other elements and to enable different load combinations to be applied, or to carry out both the structural analysis and prestress design.

The basic principles of prestressed concrete design can be simply understood by considering the stress distribution in a concrete section under the action of externally applied forces or loads. It is not intended here to provide a detailed explanation of the theory of prestressed concrete design, but Figure 5.1 outlines the principles.

The example shown on the right is included to illustrate the simplicity of the basic theory. In essence, the design process for serviceability entails the checking of the stress distribution under the combined action of both the prestress and applied loads, at all positions along the beam, in order to ensure that both the compressive and tensile stress are kept within the limits stated in design standards.

In addition the technique known as 'load balancing' offers the designer a powerful tool. In this, forces exerted by the prestressing tendons are modelled as equivalent upward forces on the slab. These forces are then proportioned to balance the applied downwards forces (Figure 5.2). By balancing a chosen percentage of the applied loading it is possible to control deflections and also make the most efficient use of the slab depth.

Consider a beam with a force  $P$  applied at each end along the beams' centre line.

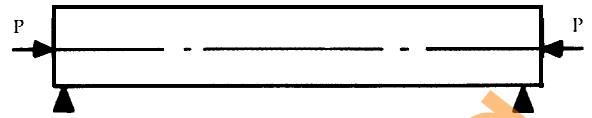

This force applies a uniform compressive stress across the section equal to  $P/A$ , where  $A$  is the cross sectional area. The stress distribution is shown below.



Consider next a vertical load  $W$  applied to the section and the corresponding bending moment diagram applied to this alone.

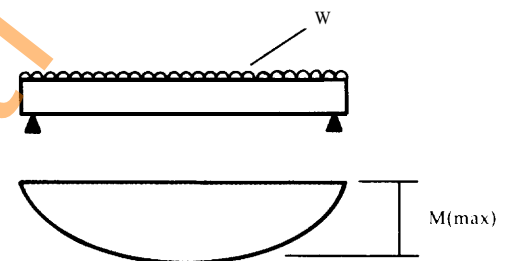

The stress distribution from the flexure of the beam is calculated from  $M/Z$  where  $M$  is the bending moment and  $Z$  the section modulus. By considering the deflected shape of the beam it can be seen that the bottom surface will be in tension. The corresponding stress diagram can be drawn.

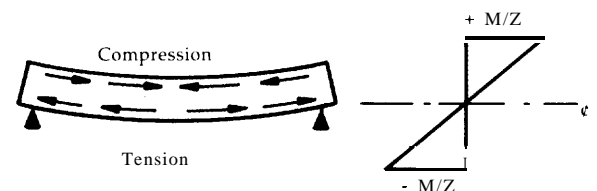

Concrete is strong in compression but not in tension. Only small tensile stresses can be applied before cracks that limit the effectiveness of the section will occur. By combining the stress distributions from the applied precompression and the applied loading it can be seen there is no longer any tension.

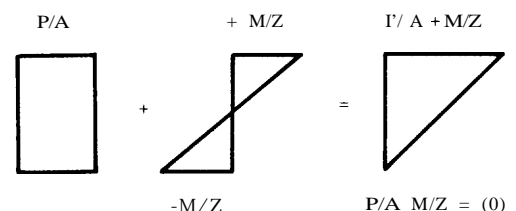

Figure 5.1 Principles of prestressed design

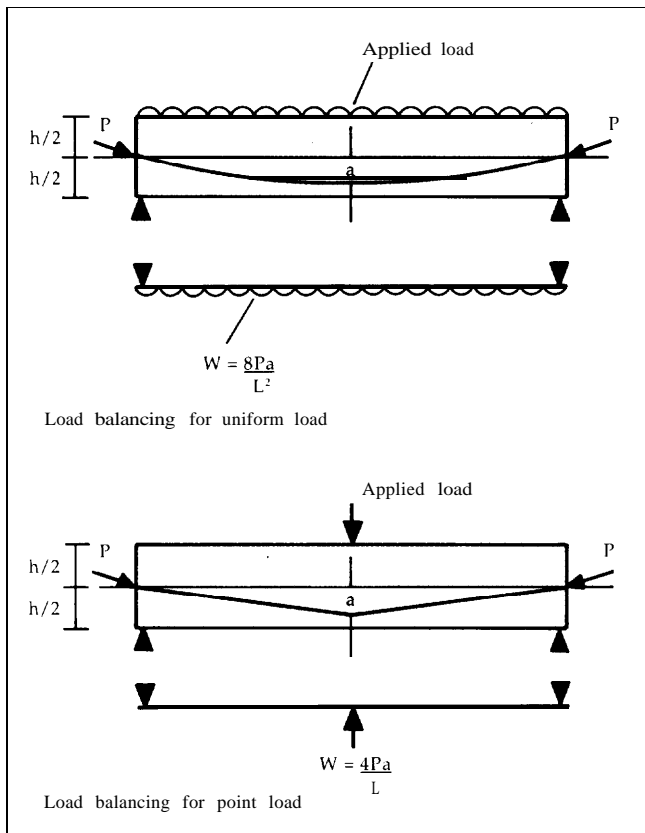

Figure 5.2 Load balancing of unbonded tendons in flat slab

In order to use the load balancing technique, the prestressing tendons must be set to follow profiles that reflect the bending moment envelope from the applied loadings. Generally parabolic profiles are used. In the case of flat soffit slabs these are achieved by the use of supporting reinforcing bars placed on proprietary chairs (Figure 5.3 (a) and (b)).

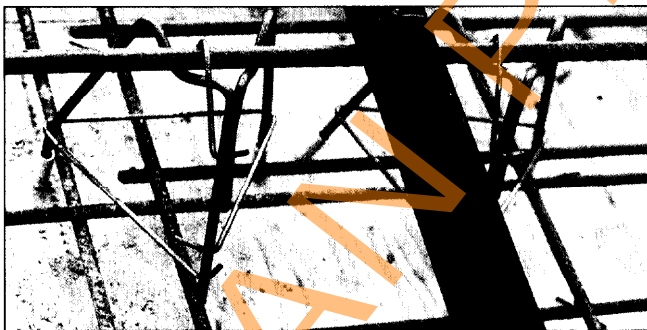

Figure 5.3(a) Wire chairs

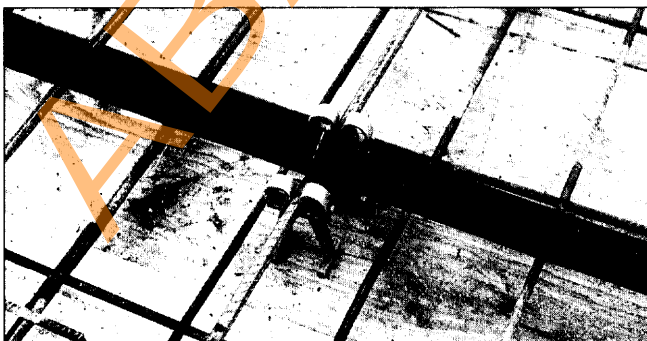

Figure 5.3(b) Plastic chairs for smaller cover

The supporting bars are fixed rigidly into position and then the prestressing tendons laid and secured to them in order to obtain the desired profile (Figure 5.4). Tendon support bars are required at a maximum of one metre centres. With deeper ribbed slabs the required profile is obtained by tying the tendons to short lengths of bar wired to the reinforcement links which are spaced off and supported by the formwork.



Figure 5.4 Tendon profile obtained by varying height of chairs

In the majority of prestressed slabs it will be necessary to add reinforcement, either to control cracking or to supplement the capacity of the tendons at the ultimate load condition. In one-way spanning slabs it is normal practice to provide sufficient bonded reinforcement to carry the selfweight plus a proportion of the imposed loading on the slab. This is to cater for the possibility of the loss of prestress in any one span resulting in the progressive collapse in the other spans. Tests have shown that in a two-way spanning slab there is a high degree of inherent structural redundancy with the local loss of prestress in one span having very little affect on other spans (0).

At the serviceability limit state, a prestressed slab is generally always in compression and therefore flexure cracking is uncommon. This allows the accurate prediction of deflections as the properties of the untracked concrete section are easily determined. Deflections can therefore be estimated, and limited to specific values rather than purely controlling the span-to-depth ratio of the slab, as in reinforced concrete design.

In post-tensioned concrete floors, the load balancing technique can enable the optimum depth to be achieved for any given span. The final thickness of the slab, as with thin solid slabs, may be determined by consideration of the punching shear around the column. Traditionally, dropped panels or column heads were used to cater for this shear, but recent research and development has led to the manufacture of prefabricated shear reinforcement and steel shear heads (11) (Figures 5.5 and 5.6). These then allow the use of totally flat soffits (Figure 5.5) which gives obvious benefits both in terms of reduced overall depth, ease of service distribution and speed of construction.

In an effort to reduce still further the weights of prestressed slabs, lightweight aggregate concretes can be used. These give obvious benefits in terms of reduced selfweight and foundation loads.

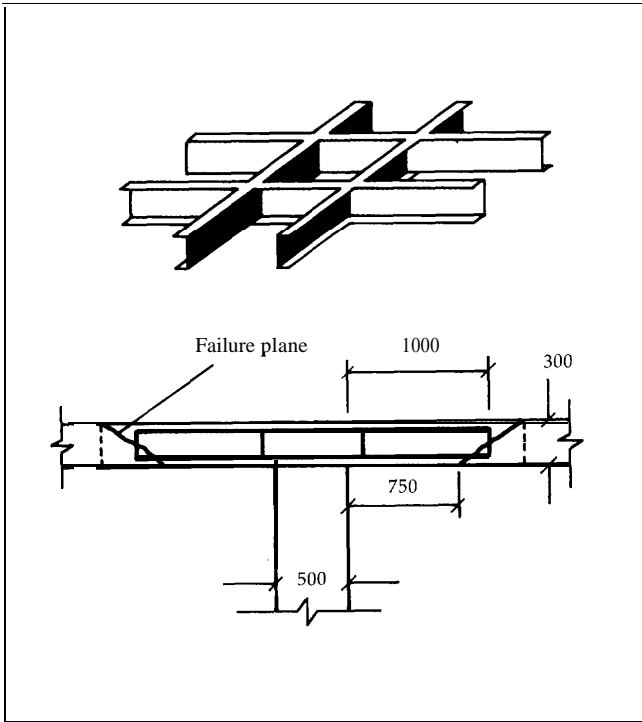

Figure 5.5 Typical shearhead detail



Figure 5.6 Steel shearhead in post-tensioned floor slab

Partial prestressing, which combines some prestressing with the structural action of a traditional reinforced section, can also be economic. This form of construction can accommodate high tensile stresses at full design loading with the following benefits.

The non-prestressed steel helps crack control before stressing is applied.

Transfer stress problems are eliminated.

If restraint or over-loading occurs, any cracks are better distributed.

Deflection control and high span/depth ratios are maintained.

Lower tendon density improves space for penetrations.

## Restraint

When planning a prestressed concrete structure, care must be taken to avoid the problems of restraint<sup>(12)</sup>. This is where the free movement in the length of the slab under the prestress forces is restrained, for example by the unfavourable positioning of shear walls (Figure 5.7(a)) or lift cores.

There are two components to the applied prestress: the direct axial compression in the concrete section transferred through the tendon anchorage, and the upward force from the tendon profile. If the slab is restrained when the slab is stressed, force may be lost into the restraining element instead of being fully transferred to the slab. This may result in a loss of axial compression but will not affect the upward force. A significant loss of axial compression force could cause the slab to crack.

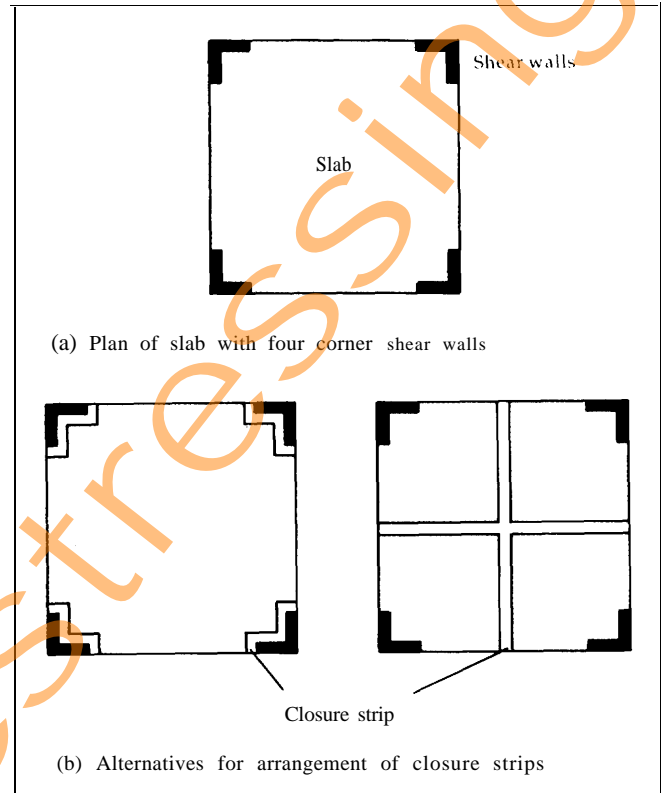

Restraint problems are not common, as the levels of prestress are low, and well tested and simple methods are used, for example closure strips as shown in Figure 5.7(b) Wall infill strips (Figure 5.8) or temporary release details (Figure 5.9) are available for overcoming potential restraint problems. Movement joints can also be incorporated when required.

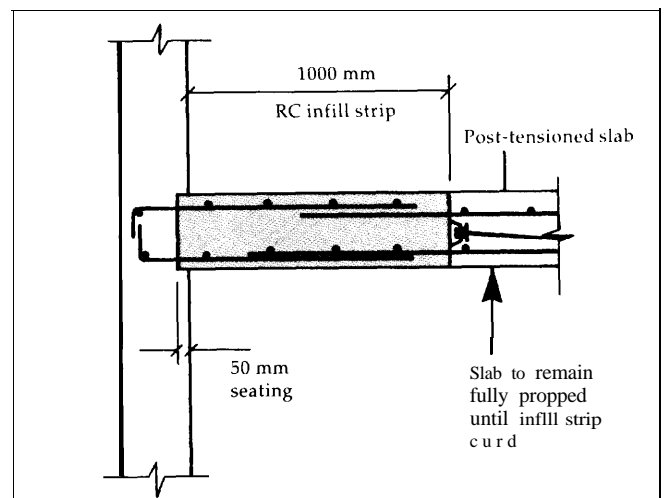



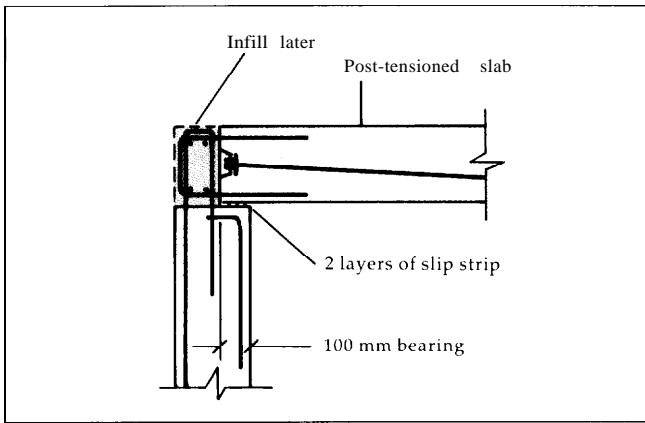

Figure 5.9 Temporary release detail at top of supporting wall

## Holes

A particular design feature of post-tensioned slabs is that the distribution of tendons on plan within the slab does not significantly effect its ultimate strength. There is some effect on strength and shear capacity, but this is generally small. This allows an even prestress in each direction of a flat slab to be achieved with a number of tendon layouts (Figure 5.10(a-c)).

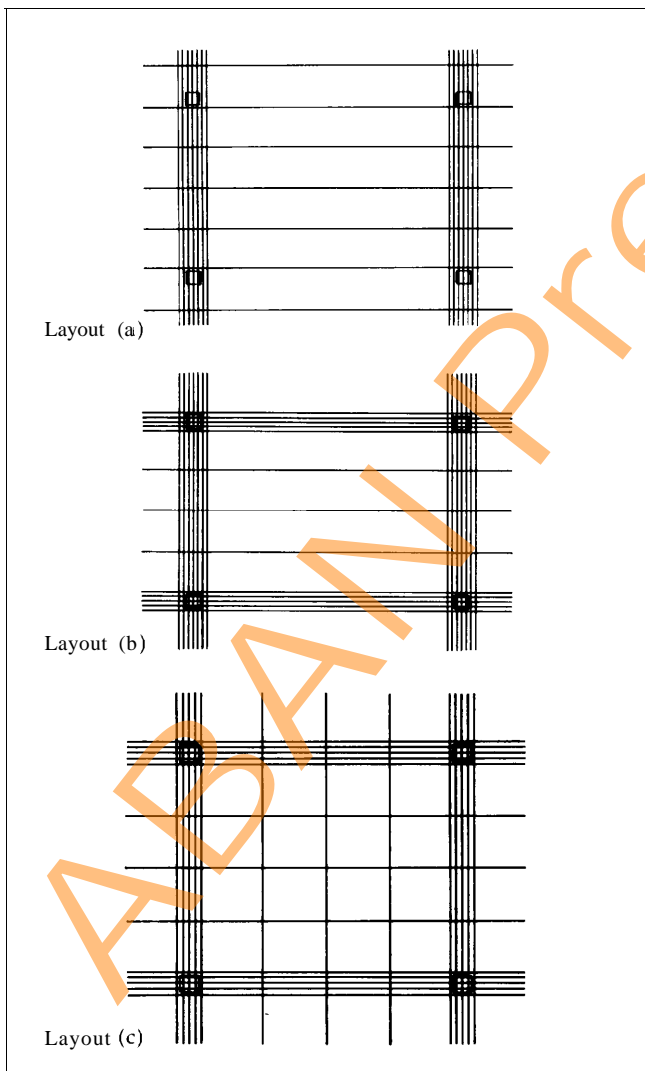

Figure 5.10 Common layouts of unbonded tendons in flat slab

This offers considerable design flexibility to allow for penetrations and subsequent openings, and the adoption of differing slab profiles, from solid slabs through to ribbed and waffle construction.

Figure 5.10(a) shows the layout of tendons banded over a line of columns in one direction and evenly distributed in the other direction. This layout can be used for solid slabs, ribbed slabs, or band beam and slab floors. It offers the advantages that holes through the slab can be easily accommodated and readily positioned at the construction stage.

Figure 5.10(b) shows the tendons banded in one direction, and a combination of banding and even distribution in the other direction. This does not provide quite the same flexibility in positioning of holes, but offers increased shear capacity around column heads. Again, this layout can be used for both solid and ribbed slabs and banded beam construction.

Figure 5.10(c) shows banded and distributed tendons in both directions and is logically suitable for waffle flat slabs, but may be employed for other slabs, depending on design requirements.

Holes through prestressed slabs can be accommodated easily if they are identified at the design stage. Small holes (less than 300 mm x 300 mm) can generally be positioned anywhere on the slab, between tendons, without any special requirements. Larger holes are accommodated by locally displacing the continuous tendons around the hole (Figure 2.7). It is good detailing practice to overlap any stopped off (or 'dead-ended') tendons towards the corners of the holes in order to eliminate any cracking at the corners (Figure 5.2 1). In ribbed slabs, holes can be readily incorporated between ribs or, for larger holes, by amending rib spacings or by stopping-off ribs and transferring forces to the adjoining ribs.

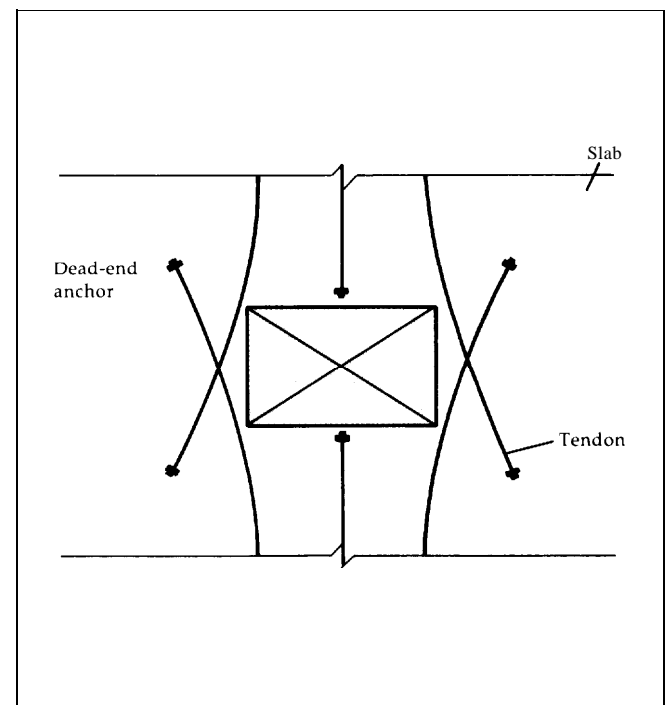

Holes are more difficult to accommodate once the slab has been cast. They can, however, be carefully cut if the tendon positions have been accurately recorded or can be identified (see Section 7). A better approach is to identify at the design stage zones where further penetrations may be placed. These zones can then be clearly marked on the soffit of the slab.

## 6 CONSTRUCTION

Many of the major specialist concrete frame contractors have experience with post-tensioned construction, and are aware of how it differs from using reinforced concrete and the benefits it offers. Those contractors less familiar may be wary as there is definitely a learning curve to be climbed in the early stages of a project. However, experience shows that once in their stride, all contractors can achieve exceptional floor cycles with post-tensioned construction.

### Aspects of construction

The sequence of construction of post-tensioned slabs is straightforward and typically includes the points given below. A number of aspects such as prefabrication of tendons, the reduction in quantities of steel to be fixed and large pour sizes help to speed the construction.

#### Prefabrication of tendons

In the case of an unbonded system, fabrication drawings are produced from which each tendon is cut to length and assembled off-site with any dead-end anchorages. Tendons are individually colour-coded and delivered to site in coils ready to be fixed (Figure 6.1). With a bonded system the ducting and tendons are cut and assembled on site.



Figure 6.1 Colour-coded tendons ready for fixing

#### Sequence of installation

In any slab there will be both reinforcement and tendons to be fixed (Figure 5.4). The fixing sequence is generally: (1) fix bottom mat reinforcement, (2) fix tendon support bars to specified heights, (3) drape tendons across the support bars and secure, and (4) fix any top mat steel and column head reinforcement.

### Construction joints

There are three types of construction joint that can be used between areas of slab; these are shown in Figure 6.2(a-c). When used they are typically positioned in the vicinity of a quarter or third points of the span. The most commonly used joint is the infill or closure strip, as this is an ideal method of resolving problems of restraint, and it also provides inboard access for stressing, removing the need for perimeter access from formwork or scaffolding.

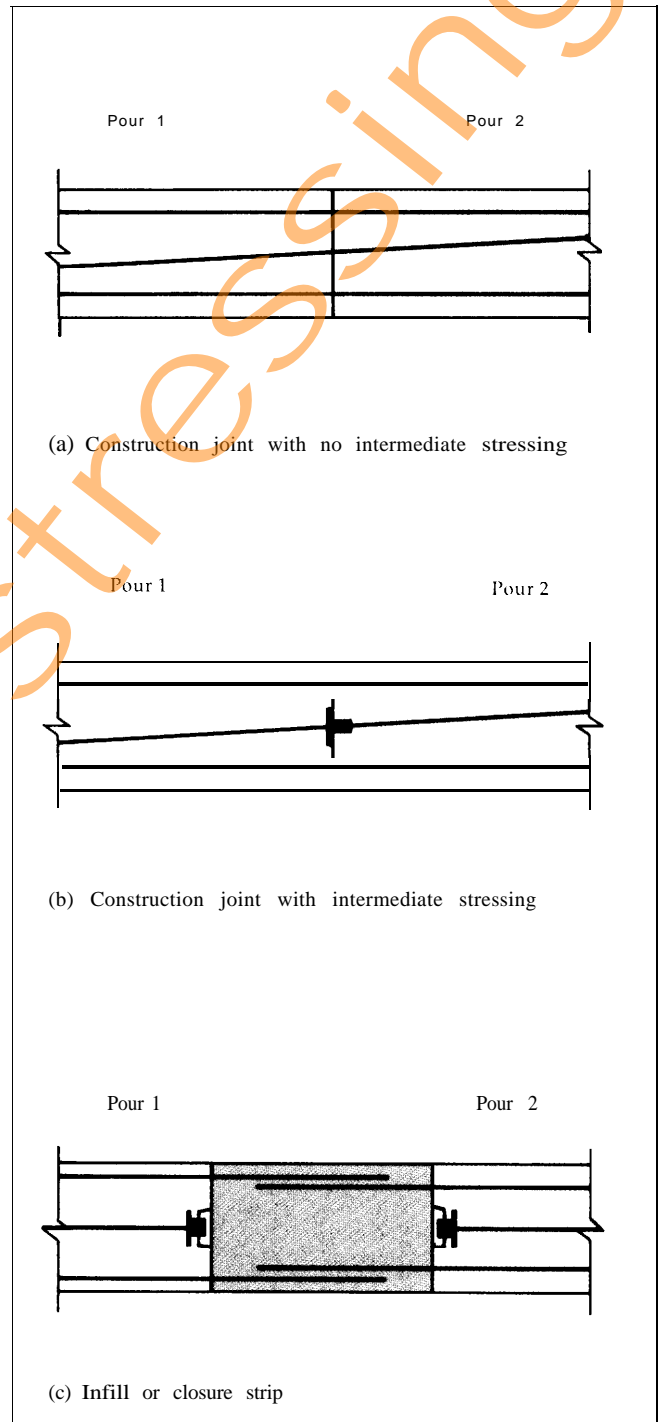

Figure 6.2 Details of slab construction joints

Construction joint with no stressing (6.2(a))

The slab is cast in bays and stressed when all the bays are complete. For large slab areas, control of restraint stresses may be necessary and ideally the next pour should be carried out on the following day.

### Construction joint with intermediate stressing (6.2(b))

On completion of the first pour containing embedded bearing plates, intermediate anchorages are fixed to allow the tendons to be stressed. After casting of the adjacent pour, the remainder of the tendon is stressed. It is sometimes necessary to leave a pocket around the intermediate anchorage to allow the wedges that anchor the tendons during the first stage of stressing to move during the second stage of stressing.

### Infill or closure strips (6.2(c))

The slabs on either side of the strip are poured and stressed, and the strip is infilled after allowing time for temperature stresses to dissipate and some shrinkage and creep to take place.

### Pour size/joints

Large pour areas are possible in post-tensioned slabs, and the application of an early initial prestress, at a concrete strength of typically  $12.5 \text{ N/mm}^2$ , can help to control restraint stresses. There are economical limits on the length of tendons used in a slab, and these can be used as a guide to the maximum pour size. Typically these are 35 m for tendons stressed from one end only and 70 m for tendons stressed from both ends.

The slab can be divided into appropriate areas by the use of stop ends (Figure 6.3) and, where necessary, bearing plates are positioned over the unbonded tendons as shown in Figure 6.4 to allow for intermediate stressing.

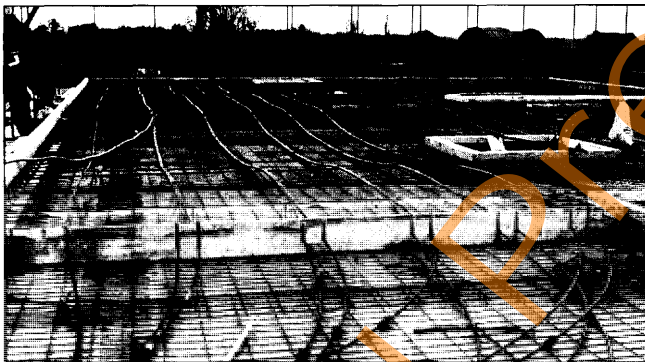

Figure 6.3 Positioning of stop ends to divide slab into bays



Figure 6.4 Bearing plates positioned over tendons

### Concreting

Care must be taken when concreting (Figure 6.5) to prevent operatives displacing tendons, but apart from this, both the placing and curing of the concrete is similar to that for a reinforced slab, although concreting is easier as there is no reinforcement congestion.



Figure 6.5 Placing concrete in post-tensioned slab

### Stressing

Concrete cubes are taken and cured close to the slab to enable the strength gain of the concrete to be monitored. The cubes are taken during the pour and crushed at daily intervals to monitor the strength gain of the concrete. At about one to three days, when the concrete has attained a strength of typically  $12.5 \text{ N/mm}^2$ , initial stressing of tendons to about 50% of their final jacking force is carried out. (The actual concrete strength and tendon force will vary depending on loadings, slab type and other requirements.) These control restraint stresses and may also enable the slab to be self-supporting so that formwork can be removed. Design checks on the frame are necessary, taking account of the reduced concrete strength, and it is recommended that as soon as the formwork has been removed a secondary propping system is used until the slab is fully stressed.

With an unbonded system stressed from one end, the remote end is fixed by a dead-end anchorage (Figure 6.6).



Figure 6.6 Dead-end anchorage



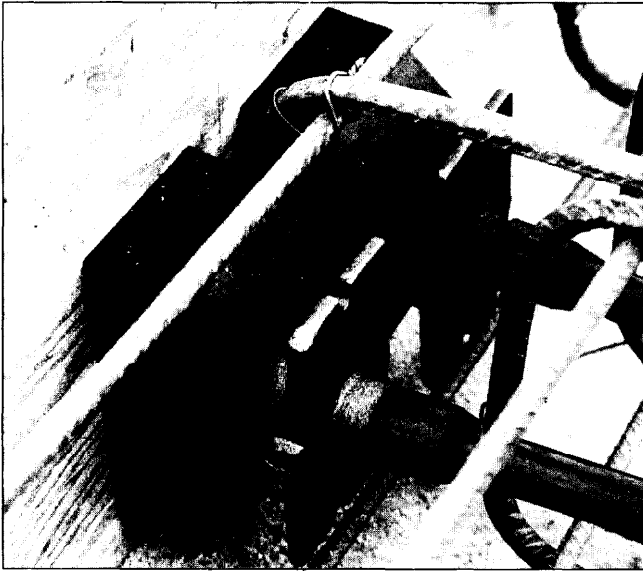

**Figure 6.7** Stressing anchorage assembled with plastic recess form

At the stressing end the tendon passes through a bearing plate and anchor which is attached to the perimeter form by a mandrel holding in place a reusable plastic recess form (Figure 6.7).



**Figure 6.8** Stressing of tendons



**Figure 6.9** Recessed anchorages showing wedges

The tendon is stressed with a hydraulic jack (Figure 6.8), and the resulting force is locked into the tendon by means of a split wedge located in the barrel of the recessed anchor (Figure 6.9).

The anchors shown are for a single unbonded tendon. Anchorages for use with bonded tendons differ in detail, but perform the same general function. At about seven days, when the concrete has attained its design strength (typically 25 N/mm<sup>2</sup>) the remaining stress is applied to the tendons.

The extension of each tendon under load is then recorded and compared against the calculated value. Provided that it falls within an acceptable tolerance, the tendon is then trimmed. With an unbonded system, a greased cap is placed over the recessed anchor and the remaining void dry-packed. With a bonded system the anchorrecess is simply dry-packed and the tendon grouted.

### Back propping

When designing the formwork systems for a multi-storey construction, the use of back-props (Figure 6.10), through more than one floor to support the floor under construction, should be considered.



**Figure 6.10** Back-propping of post-tensioned ribbed slab

Research into back-propping of slabs has been carried out by the Reinforced Concrete Council, and the results are to be published shortly<sup>(13)</sup>.

### Slab soffit marking

Various methods exist for marking the slab soffit to identify where groups of tendons are fixed. One way is to increase the slab thickness over the width of the group of tendons - thus creating an identifying downstand - or paint markings can be used as shown in Figure 6.11. This enables areas for small holes and fixings to be drilled after completion, safe in the knowledge that tendons will not be damaged.

Disciplines for soffit fixings can be agreed, indicating the maximum depth of fixing that can be used in any one area.

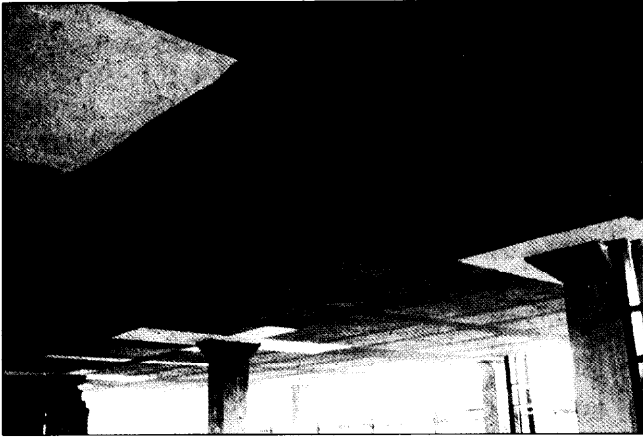

Figure 6.21 Marking of tendon positions in slab

## 7 DEMOLITION AND STRUCTURAL ALTERATIONS

Two of the most commonly considered aspects of the use of un-bonded tendons are the performance of the structure during demolition and its ability to accept structural alterations.

### Demolition

It is commonly thought that an unbonded post-tensioned slab is an ‘unexploded bomb’ that will detonate during demolition, and that the local failure of one part of a structure will lead to a total structural collapse. Research together with case studies shows that, in structures designed in accordance with current standards and good practice, the above concerns are unfounded.

Experience on actual buildings and in laboratory tests shows that when tendons are cut as a result of, for example, partial collapse, the failure will not result in anchorages, lumps of concrete, or other material becoming missiles. The scatter of debris will be no more severe than in the collapse of an equivalent non-stressed structure.

During controlled demolitions, as with any structure, safety precautions are necessary, and de-tensioning must be carried out by an experienced demolition contractor. Several tried and tested techniques are available for de-tensioning. The most common are:

- Heating the wedges until tendon slip occurs
- Breaking out the concrete behind the anchorage until de-tensioning occurs
- De-tensioning the strand, using jacks.

Because of the usual site problems of access and other constraints it is often necessary to use a combination of techniques.

With regard to the concern that local failure could lead to total collapse, again results from both tests and case studies are available which demonstrate that total collapse does not happen<sup>(10)</sup>.

During demolition, or if a partial collapse occurs, a two-way spanning structure is likely to behave differently from a one-way spanning structure. A large, multi-bay, two-way, flat slab has a very high degree of inherent structural redundancy. This redundancy, coupled with the possibility of catenary action of the slab between columns, gives very high ultimate strength that is significantly above that determined by calculation. It has been proved that the loss of prestress in, for example, one panel of the slab will not result in a failure of either the panel concerned or the structure as a whole<sup>(10)</sup>.

However, in a continuous one-way spanning slab the loss of prestress in one span could result in a similar loss in other spans, and result in failure if the slab is prestressed only. Design standards take account of this possibility, and the usual approach is to provide sufficient normal bonded reinforcement within the slab to support the self-weight of the slab and finishes and a proportion of the imposed load.

### Structural alterations

Some views on the ability of post-tensioned slabs to accommodate minor alterations, such as core drilling service holes, or more major alterations like forming large openings for escalators, suggest that such alterations to other forms of construction are straightforward. The truth is that in all cases any alteration that affects the existing structure needs to be carefully considered and designed by an engineer. For example, coring a hole through a reinforced concrete slab, which cuts through a reinforcing bar, will reduce the strength of that slab. Similarly, forming a large opening in any structure will require the effects on adjacent areas of the structure to be assessed, and may require the introduction of additional support members to ensure that the overall structural integrity is maintained.

Forming smaller openings through post-tensioned slabs can be more straightforward than in other structures. In solid slabs the tendons are usually regularly spaced across the slab with quite large gaps between, and holes may readily be formed between ribs of ribbed slabs (Figure 7.1).

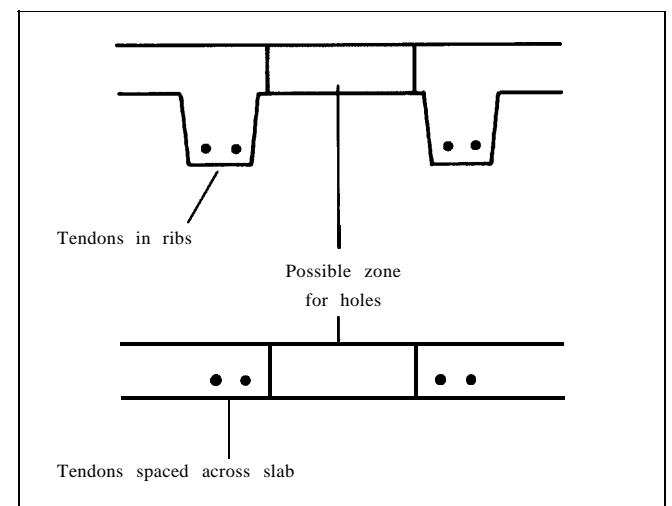

Figure 7.2 Zones where holes can be readily formed in post-tensioned slabs

Methods exist for marking the slab soffit to identify tendon locations (Figure 6.11). Once this has been done, small holes can be formed in the 'clear' zones without any detrimental effect on the structural performance.

Even when a soffit marking and other zoning systems are used it is recommended that the position of each proposed hole is referred back to the designer for comment and approval.

When forming large openings in structures after initial construction, regard must be given to the original design concept. Post-tensioned slabs are no different from other forms of construction in this respect.

Providing a large hole in a slab with bonded tendons is not a problem, since the operation is similar to that for a reinforced section. Therefore attention is given here only to forming a large hole through a slab with unbonded tendons. Figure 7.2 illustrates the typical stages involved.

In forming larger openings it is likely that more than one group of tendons will be affected and will need to be removed. As mentioned above, techniques already exist for de-tensioning; similarly, there are techniques available for re-anchoring tendons and re-tensioning. It is therefore possible to remove tendons which cross an opening without affecting the remaining areas of the slab which those same tendons pass through and support.

At a practical level, the main effect with unbonded tendons is that areas of slab remote from the area under consideration, but affected by de-tensioning, will need to be fully propped for the duration of the work.

When considering a flat slab design, it will generally be necessary to locate openings away from areas of banded tendons, typically beam strips, in order to minimise any reinstatement that may be required. This does not unduly restrict internal planning, since it is normal for around two thirds of the floor to contain tendons that are widely spaced, thus reducing the number which will intersect any intended hole (Figure 7.2(a)). Even in two-way spanning slabs there is considerable space for holes between tendons.

The eventual cutting of the tendons will temporarily reduce the load capacity of the slab for the entire length of the unbonded tendons. Effects are minimal at some distance from the anchor points since the slab remains effectively prestressed by the other tendons. In most circumstances it is sufficient simply to restrict loadings on the slab during the operation thus avoiding the need for anything other than local propping.

Prior to starting any breaking out, it is necessary to locate the tendon positions. The tendons are usually located singly or in pairs at approximately 1 m centres, and may be found using an appropriate cover meter. A small hole is usually broken to expose the tendon about 400 mm from the final face of the opening. Alternatively, the surrounding concrete can be broken away exposing the tendons along the entire length of the opening (Figure 7.2(b)). It is usual to have an engineer present during this stage of the operation to ensure that no premature damage occurs to the tendons.

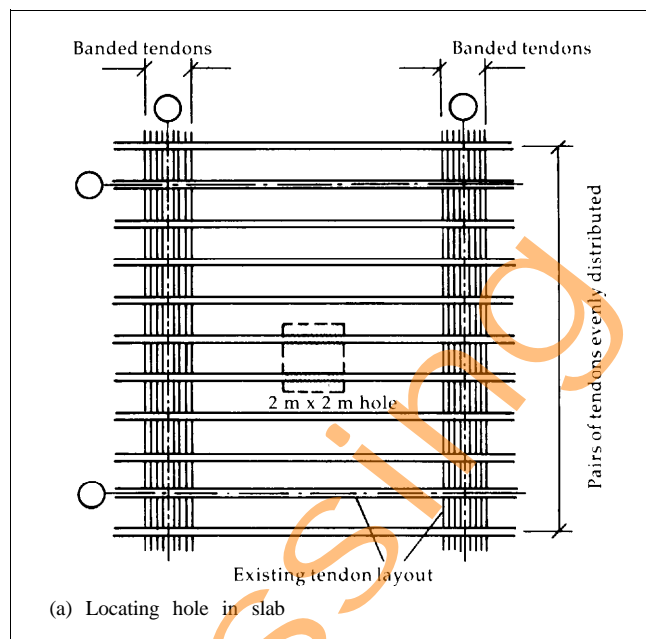

Figure 7.2 Forming large openings post-construction

The uncovered tendons can then be de-tensioned one by one (Figure 7.2(b)). The strands are usually flame-cut within this hole, as this causes the strand to yield rather than break suddenly. Alternatively the tendon can be cut using a disc. In this case the procedure is to slip a bearing plate over the tendon and against the concrete face. Special jacks are then positioned against the bearing plates and used to take up the load in the tendon. This relieves the load in the length of the tendon between the jacks. The tendon is then cut and the pressure gradually released from the jacks until the tendon is completely de-tensioned.

In both cases, the strand will draw back slightly into the sheath when cut, depending on the stressed length. With all the strands cut in the area required, all the remaining concrete can be broken out back to the final face. This is achieved more easily than with a reinforced concrete slab since the reinforcement quantities are minimal.

Having stripped back the sheathing, a standard anchorage can then be fitted to the tendon. This is set into the parent concrete using a fast-setting epoxy or cementitious mortar (Figure 7.2(c)). Once the mortar has set the tendon may be restressed. When restressing is completed satisfactorily, the excess tendon is cut off and capped.

Once the anchors are reinstated, further work is mainly cosmetic. Any desired edge profile can be formed, eg nib or upstand using a small cage of links around the perimeter. (Figure 7.2(d)). Pouring concrete into the edge strip completes the operation. An example of a hole formed after construction to accommodate a spiral staircase is shown in Figure 7.3.

The above technique is a method of forming a large hole in a post-tensioned flat slab. The slab may be wholly prestressed or combined with reinforced concrete. For example, McAlpine's offices at Hemel Hempstead (shown in Figure 7.4) were constructed with post-tensioned band beams, with a reinforced coffer slab between, that allowed a 4 m x 4 m hole to be broken out for an atrium without structural modification.

**It cannot be over-emphasised that a slab may be designed to accommodate a wide range of future alterations, whether these are predetermined or not.**

As has been shown, introducing large holes into a post-tensioned slab is straightforward, and can be carried out in a similar time to that taken for a reinforced slab.

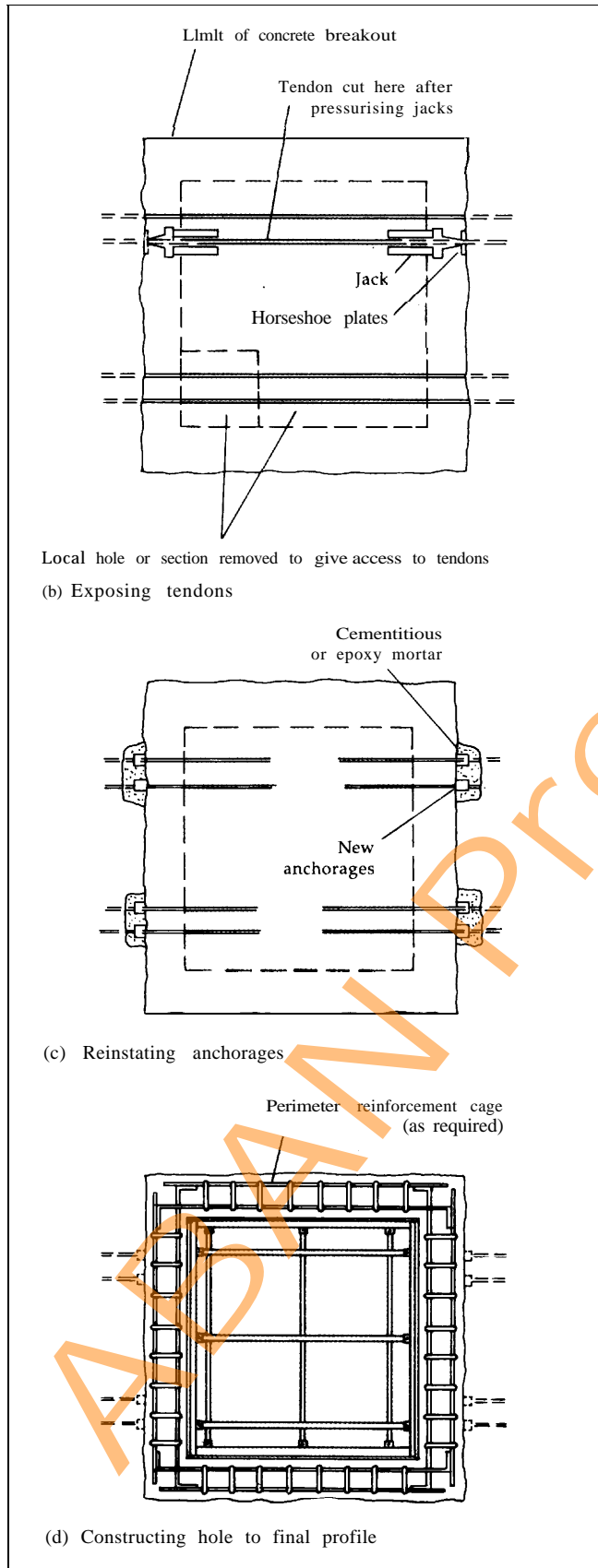

Figure 7.2 Continued

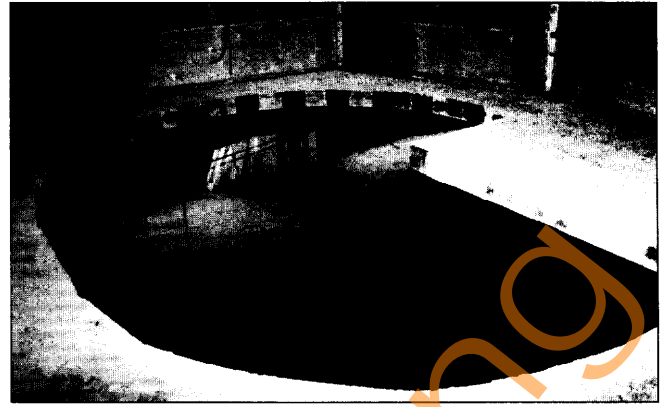

Figure 7.3 Example of hole formed post-construction



Figure 7.4 Atrium formed post-construction

## REFERENCES 8

1. REINFORCED CONCRETE COUNCIL. *Concrete - the high Speed building option*. Wexham Springs (now Crowthorne), British Cement Association (on behalf of the Reinforced Concrete Council), 1989. 6 pp. (Pub. INF 087).
2. BENNETT, D. F. H. *Advances in concrete construction technology*. Wexham Springs (now Crowthorne), British Cement Association (on behalf of the Reinforced Concrete Council), 1990. 16 pp. (Pub. 97.309).
3. MATHEW, P. & BENNETT, D.F.H. *Economic long span concrete floors*. Wexham Springs (now Crowthorne), British Cement Association (on behalf of the Reinforced Concrete Council), 1990. 48 pp. (Pub. 97.311).
4. BENNETT, D. F. H. & BILLINGHAM, A. *Project Profile - Exchange Tower*. Wexham Springs (now Crowthorne), British Cement Association (on behalf of the Reinforced Concrete Council), 1991. 12 pp. (Pub. 97.315).



5. GERWICK, B. C. *Construction of prestressed concrete structures*. 2 Ed. Chichester, John Wiley & Sons Inc. 1993. 591 pp.
6. BRITISH STANDARDS INSTITUTION. *Structural use of concrete*. Part 1 Code of practice for design and construction. BS 8110 :Part 1: 1985. London, BSI, 1985.
7. CONCRETE SOCIETY. Flat slabs in post-tensioned concrete with particular regard to the use of unbonded tendons. *Design recommendations*. Technical Report No. 17. Wexham, The Concrete Society, 1979. 16 pp.
8. CONCRETE SOCIETY. *Post-tensioned flat-slab design handbook*. Technical Report No. 25. Wexham, The Concrete Society, 1984. 44 pp.
9. CONCRETE SOCIETY. *Post tensioned concrete floors. Design handbook*. Technical Report No. 43. Wexham, The Concrete Society, 1994. 160 pp.
10. FREYERMUTH, C. L. Structural integrity of buildings constructed with unbonded tendons. *Concrete International*, Vol. 11, No. 3, March 1989. pp. 56-63.
11. BRITISH CEMENT ASSOCIATION. R. C. *Review - Structural concrete updates*. Wexham Springs (now Crowthorne), British Cement Association (on behalf of the Reinforced Concrete Council), 1990.6 pp. (Pub. 97.314).
12. AALAMI, B. I. & BARTH, F. G. Restraint cracks and their mitigation in unbonded post-tensioned building structures in ACISP - 113, *Cracking in prestressed concrete structures*. Detroit, ACI, 1989. pp. 157-202.
13. BEEBY, A. *Fast floor cycle design for structural and temporary works designers*. Crowthorne, British Cement Association (on behalf of the Reinforced Concrete Council), 1994. Publication pending. (Pub. 97.351).

**POST-TENSIONED CONCRETE FLOORS IN MULTI-STOREY BUILDINGS**

A M Stevenson

BRITISH CEMENT ASSOCIATION PUBLICATION 97.347

CI/SfB

UDC

69.025.2:24.102.46

ABAN Prestressing

