

MEASUREMENTS/ SPECIFICATIONS

Conversion Formulas

USE THE 50, 75 OR 200 GPM TESTER TO SIMULATE ACTUAL OPERATING CONDITIONS OF THE SYSTEM UNDER TEST

Testing the pump: Operator runs engine at a specific rpm and adjusts tester's pressure compensating valve to simulate a work load. By comparing meter readings with manufacturer specs, proper operation of pump can be confirmed. If oil flow and pressure do not meet specs, the pump is faulty. Or, if test results and specifications agree, the operator will know that the problem is elsewhere in the system and that other tests must be performed. Regardless of the component being tested, hook-up and testing is accomplished in minutes. NOTE: These hydraulic testers should always be used with the owner's manual/manufacturers' specifications for the system under test.

Cyl. Caps furnished with "C" Series Cylinders:

5 ton cylinders	No. 201375
10 ton cylinders	No. 201362
15 ton cylinders	No. 201362
25 ton cylinders	No. 201412
55 ton cylinders	No. 36161
75 ton cylinders	No. 36161
100 ton cylinders	No. 36161

PERFORMANCE

The table at right gives you an idea of what to expect when coupling RD series cylinders to a Power Team pump. Actual performance will vary according to job conditions.

Pump	Cylinder	Time to Extend Cylinder 1"	
		100 psi	10,000 psi
PE55	RD55	1.0 sec.	12.0 sec.
	RD100	1.8 sec.	22.5 sec.
	RD200	3.5 sec.	45.0 sec.
	RD400	7.2 sec.	85.0 sec.
PQ120 Series	RD200	3.4 sec.	20.6 sec.
	RD300	4.9 sec.	30.0 sec.
	RD400	6.4 sec.	39.0 sec.
PE400 Series	RD300	3.0 sec.	8.5 sec.
	RD400	3.9 sec.	11.1 sec.
	RD500	4.9 sec.	14.1 sec.

NOTE: Base mounting holes are standard on all RD cylinders. Orientation of base mounting holes to coupler. Orientation on RD300, RD400 & RD500 series is random.

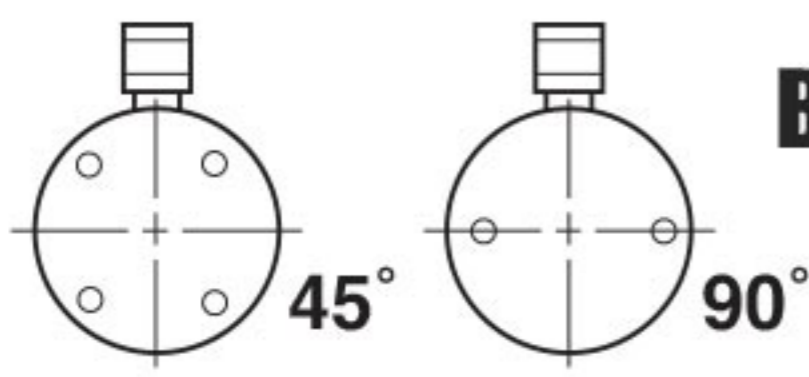

BASE MOUNTING HOLES FOR "RD" CYLINDERS

Tonnage	10	25	55	80	100	150	200	300	400	500
No. of Holes	2	4	4	4	4	4	4	4	4	6
Thread Size	3/8"-16	1/2"-13	5/8"-11	5/8"-11	3/4"-10	1"-8	1 1/4"-7	1 1/4"-7	1 1/2"-12	1 3/8"-12
Depth	5/8"	3/4"	7/8"	7/8"	1"	1"	1 1/4"	1 3/4"	1 7/8"	2"
B.C. Dia.	2"	2 3/4"	3 1/2"	4 1/2"	5 1/2"	6"	6 1/2"	6 1/4"	7 1/4"	8"
Orientation	Consult the factory.									

MOUNTING HOLES FOR "RLS" CYLINDERS

RLS50	1 1/32" C'bore x 1/4" deep, 7/32" thru hole	RLS200	39/64" C'bore x 13/32" deep, 13/32" thru hole	RLS500S	45/64" C'bore x 1/2" deep, 15/32" thru hole	RLS1000S	51/64" C'bore x 9/16" deep, 17/32" thru hole
RLS100	27/64" C'bore x 11/32" deep, 9/32" thru hole	RLS300	39/64" C'bore x 7/16" deep, 13/32" thru hole	RLS750S	51/64" C'bore x 9/16" deep, 17/32" thru hole	RLS1500S	13/16" C'bore x 9/16" deep, 17/32" thru hole

POST TENSION/STRESSING JACK DIMENSIONS

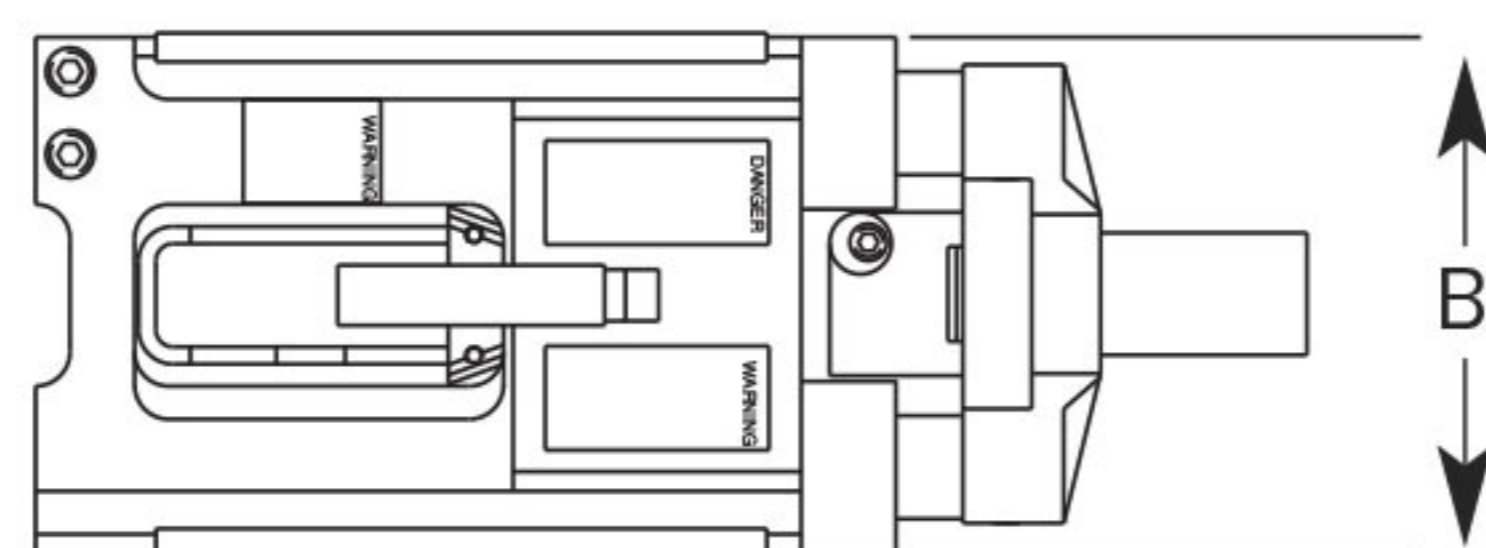
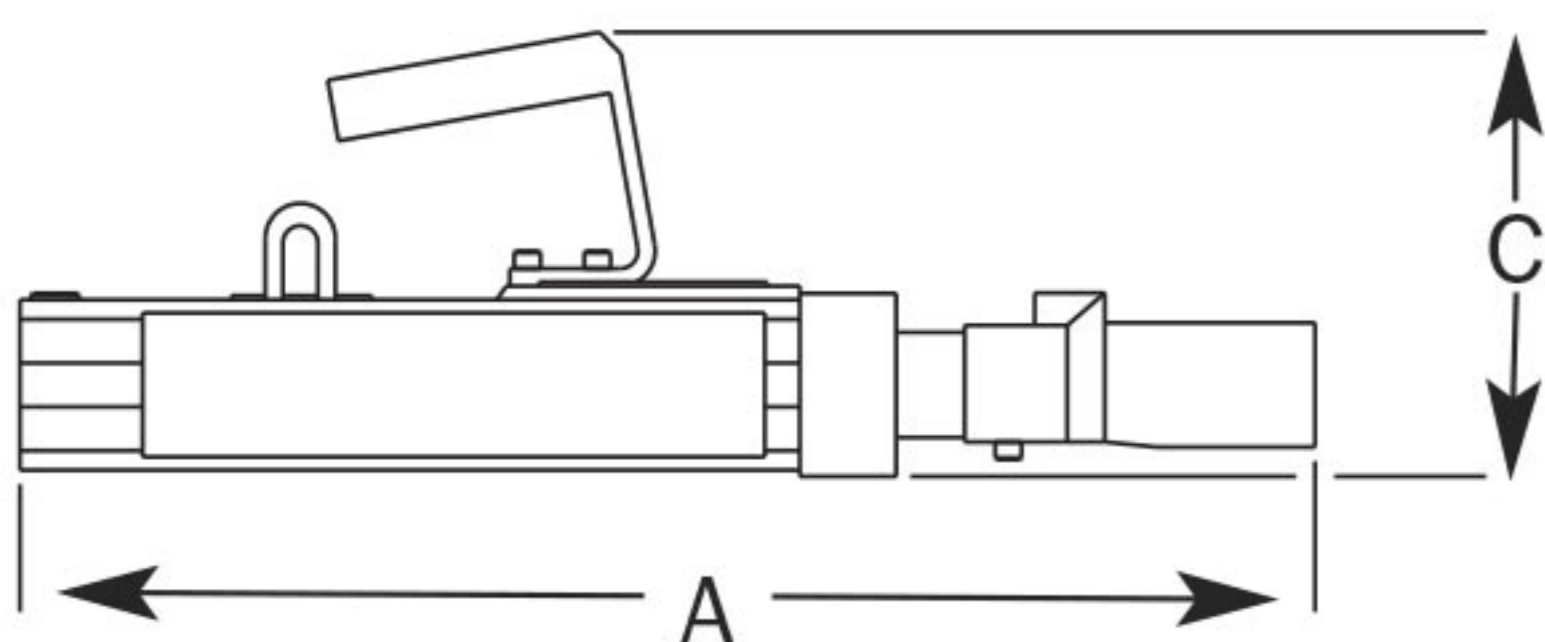

Order Number	A (in.)	B (in.)	C (in.)	Weight (lbs.)
SJ2010	21	9	6 1/2	55
SJ2010	22	10 13/64	7	76
SJ3010	22	10 13/64	7	76
SJ3010P	22	10 13/64	7	76
SJ2010DA	18 1/2	7 1/2	6 1/2	42
SJ3010DA	18 1/2	8 1/2	6 1/2	52

RESOURCES